

enomatic®

wine serving systems



roma Unica 4/r
Unica 8/r

User's manual
UMM0006 Rev.01

Contents

Purpose of the manual 3
 Identification of manufacturer and dispenser.. 4
 Help service 4
 Attached documentation 4
 Glossary of terms 5
 General safety warnings 6
 Safety warnings for environmental impact 7
 General description of dispenser 9
 Description of main parts 10
 Description of cards 12
 Description of display (for backdesk) 12
 Description of display (for winecard) 13
 Description of display (Card Generator) 14
 Description of display (Manager Card) (1).... 15
 Description of display (Staff Card) (1a) 16
 “Bottle management” screen (2) 16
 “Warnings” screen (5) 17
 “Menu” screen (6) 18
 “Dispenser group” screen (7) 18
 “Info” screen (7a) 18
 “Maintenance” screen (7b) 19
 “Prices/Doses” screen (7c) 19
 “Calibration” screen (7d) 20
 “Bottle volume” screen (7e) 20
 “Settings” screen (8) 21
 “User” screen (9) 21
 “Wallpaper” screen (9a) 21
 “Local settings” screen (9b) 22
 “Brightness” screen (9c) 24
 “Buzzer volume” screen (9d) 24
 “System” screen (10) 24
 “System info” screen (10a) 25
 “Connectivity” screen (10b) 25
 “Operating method” screen (10c) 26
 “PIN management” screen (10d) 29
 “Backup/Restore” screen (10e) 29
 “Reset” screen (10f) 30
 “Refrigeration” screen (10g) 30

“Stop” screen (10h) 32
 “Manager login” screen (11) 33
 Management of dispenser from
 remote devices (S3App) 33
 Technical data 34
 Standard accessories 36
 Packing and unpacking 37
 Transportation and storage 37
 Handling and lifting 38
 Recommendations for installation
 and connection 39
 Installation and connection 39
 Dispenser start and stop procedures 44
 Preparation of wine straws 46
 First bottle insertion 47
 Bottle insertion (wine same as previous) 49
 Bottle insertion (wine different to previous) .. 51
 Dispensing procedure (**backdesk use**) 53
 Dispensing procedure (**use with winecard**)... 54
 Extended non-use 55
 Recommendations for maintenance 56
 Routine maintenance schedule 56
 Table of cleaning products 57
 Sanitisation of pour spout cap 58
 Sanitisation of wine straws 58
 Dispenser sanitisation 59
Dispenser cleaning 59
 Dispenser rinsing 60
 Dispenser emptying 60
 Cleaning of pour spout cap 61
 Cleaning of wine straws 62
 Cleaning of drip tray 63
 Cleaning of front air filter 64
 Cleaning of rear air filter 65
 Cleaning of condensate tray 66
 Replacement of external cylinder 67
 Replacement of internal cylinder 69
 Troubleshooting 71
 Licences 76

Purpose of the manual

- The use and maintenance manual, which is an integral part of the ENOMATIC® dispenser, was designed by the manufacturer to provide the necessary information to the user.
- **The “ORIGINAL INSTRUCTIONS” were prepared by the manufacturer in ITALIAN and may be translated into other languages to meet legal and/or commercial requirements.**
- **Translations made by the agent or party responsible for distribution of the dispenser in the linguistic area in question, must bear the wording “TRANSLATION OF THE ORIGINAL INSTRUCTIONS”.**
- Besides adopting good use practices, recipients must carefully read and scrupulously apply the information provided to them.
- Taking some time to read the information will help avoid risks to the health and safety of persons and economic damage.
- Keep this manual for the entire service life of the dispenser in a place known and easily accessible, ensuring it is always available when there is a need to consult it.
- The manual must always be kept together with the dispenser upon each transfer or change of ownership.
- Several illustrations in this manual may not perfectly correspond to the configuration of the dispenser delivered, without prejudice to the integrity and understanding of the information.
- The manufacturer reserves the right to make changes to the information without the obligation to communicate this in advance, provided the level of safety is not compromised.
- To highlight certain parts of the text or indicate particularly important specifications, various symbols have been used, the meaning of which is described.

Caution - Warning

The symbol indicates that suitable behaviour must be adopted so as not to jeopardise the health and safety of persons and not to cause economic damage.

Important

The symbol indicates technical and operational information of particular importance, which must not be ignored.

NOTE: The symbol is used to reinforce the concept of the relative information.

Identification of manufacturer and dispenser

The data plate shown here is applied directly on the dispenser.

- In addition to details of the manufacturer, all essential indications regarding safe operation are also provided.

1. Details of manufacturer
2. Serial number
3. Refrigerant type
4. Class
5. Network voltage and frequency
6. Gas pressure
7. Dispenser code and model
8. Read the operating instructions
9. Electrical and electronic components
10. Mark of conformity
11. Week/Year of construction

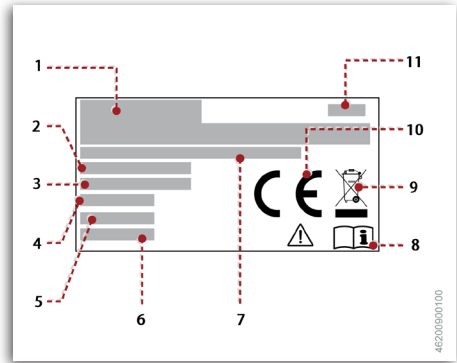

Help service

For all needs contact the **ENOMATIC® Help Service** or one of the authorised centres listed at the end of this manual.

- For all requests for technical assistance, communicate the details reported on the data plate, the approximate hours of use and type of defect found.

Attached documentation

The listed documentation is provided together with and/or attached to the manual.

- EC Declaration of conformity
- Warranty terms
- Technical data sheet ELC340-YF000, ELC380-YF000

Glossary of terms

The glossary provides a list of several terms used to draw up the information, including definitions to facilitate an understanding of their meaning.

- **Testing:** operations necessary to verify correspondence with the design specifications and to start the machine up in safe conditions.
- **Installer:** technician selected and authorised by the Manufacturer or its representative, who satisfies the requirements to carry out the installation and testing of the dispenser.
- **Maintenance technician:** technician selected and authorised to carry out works that cannot be assigned to the operator. The maintenance technician must have accurate information and recognised skills for the specific type of works.
- **Routine maintenance:** series of actions necessary to keep the dispenser and any installed devices in best working conditions. The actions are scheduled by the manufacturer, who defines the necessary skills and procedures.
- **Corrective maintenance:** necessary actions further to unexpected events that cannot be programmed by the manufacturer. Corrective maintenance works must be carried out ONLY by authorised personnel.
- **Operator:** person selected and authorised from among those having the necessary requisites, skills and information in order to use and perform routine maintenance on the dispenser.
- **Residual risks:** all risks that remain despite the safety solutions adopted and integrated during the design stage.
- **Expert technician:** person authorised by the manufacturer and/or its representative to carry out works requiring specific technical knowledge and recognised skills.
- **Carrier and handler:** authorised persons having recognised skills in the use of transport means and lifting equipment in safe conditions.
- **Intended use:** use of the dispenser in compliance with the information reported in the use and maintenance manual.
- **Foreseeable misuse:** reasonably foreseeable misuse, different to that indicated in the user manual, which may result from human behaviour.

General safety warnings

- The manufacturer, during the design and construction stages, was particularly attentive to aspects that may have generated risks to the health and safety of persons.
- During the design stage, the manufacturer, in addition to complying with the laws in force, also adopted the “rules of good construction techniques”.
- The scope of the information is to sensitise users to the importance of preventing all types of risk.
- Prudence is irreplaceable. Safety is in the hands of those who interact with the dispenser throughout its expected service life.
- **At the first start-up of the dispenser, it is recommended to carefully read the entire manual and ensure it is understood in all its parts, in particular the safety warnings.**
- Carefully read the instructions in the accompanying manual and those applied directly to the equipment, and be sure to comply with the safety instructions in particular.
- Take some time to read the instructions in order to avoid unpleasant accidents. It’s too late to remember what should have been done once an accident has already occurred.
- During lifting and handling, follow the instructions reported directly on the packaging, on the dispenser and in the manual supplied by the manufacturer.
- During installation, ensure proper ventilation in the relative area to avoid operators being exposed to a concentration of unhealthy air.
- Pay attention to the meaning of the symbols on the affixed labels; their form and colour are significant for the purposes of safety. Make sure they are always legible and respect the information indicated thereon.
- Use of the dispenser is allowed only by persons familiar with its operation and who have read and understood the contents of this manual.
- Use the dispenser only for the uses intended by the manufacturer. Misuse of the dispenser may generate risks to the health and safety of persons, as well as economic damage.
- During operation of the dispenser, ensure there are no risks to the safety of persons, in particular children and people with disabilities.
- Do not tamper with any devices to obtain performance levels different to those intended by the Manufacturer.
- DO NOT carry out works not described in this manual, rather contact a Help Service authorised by the manufacturer.
- Always use spare parts.
- Keep the dispenser in best working conditions and perform routine maintenance in accordance with the schedule and procedures indicated by the manufacturer.
- Good maintenance will ensure best performance, maximise the service life and guarantee the continued satisfaction of safety requirements.
- Do not wash the dispenser and do not direct blasts of pressurised water on the external and internal parts so as not to damage the components, in particular the electrical and electronic ones.

- Do not perform any cleaning operations with the dispenser energized.
The electrical power plug must be detached until the works have been completed.
- Do not clean the dispenser using corrosive products or abrasive materials so as not to damage the components, in particular the electrical and electronic ones
- Do not use the dispenser with the electrical cord and plug damaged or deteriorated.
- Arrange the electrical cord in such a way that it does not cause an obstruction and make sure it doesn't come into contact with hot surfaces.
- Do not make the electrical connection if the system does not comply with laws in force and if the electrical characteristics do not correspond with those of the dispenser.
- Before and after idle machine periods, cleaning and sanitisation must be carried out to guarantee adequate sanitary conditions.
- Do not install the dispenser in environments at risk of explosion and fire, near sources of heat and at risk of food contamination.
- The dispenser is fed with inert gas; in case of a leak avoid the build-up of gases.
The gases must be stored in environments with suitable ventilation and not at risk of explosion and/or fire.
- The dispenser must never be exposed to atmospheric agents and corrosive vapours.

Safety warnings for environmental impact

- Each organisation is responsible for applying the procedures to identify and control the impact of their activities (products, services, etc.) on the environment.
- The procedures to identify significant impacts on the environment must take into account the following factors.
 - Atmospheric emissions
 - Discharge of liquids
 - Waste management
 - Soil contamination
 - Use of raw materials and natural resources
 - Local problems concerning environmental impact
- In order to minimise the environmental impact, the manufacturer provides certain instructions that must be taken into account by all those, who in any capacity, interact with the product throughout its expected service life.
- All packaging components must be disposed of in accordance with the relative laws in force.
- During installation, ensure proper ventilation in the relative area to avoid operators being exposed to a concentration of unhealthy air.
- During use and maintenance, do not dispose of polluting products (oil, grease, etc.) in the environment and implement waste sorting based on the composition of the different products and in compliance with the relative laws in force.
- Keep noise levels to a minimum to reduce noise pollution.

- During decommissioning, sort all the components according to their chemical characteristics and arrange for differentiated disposal in compliance with the applicable laws in force.
- Further to the WEEE (Waste Electrical and Electronic Equipment) Directive, the user, during decommissioning, must separate the electrical and electronic components and dispose of them through authorised waste centres, or else return them still installed to the vendor when making a new purchase.
- All components that must be separated and disposed of using a specific procedure, are marked by a special symbol.

NOTE: The unlawful disposal of components covered by the WEEE (Waste Electrical and Electronic Equipment) Directive is punishable with sanctions regulated by the laws in force in the territory where the breach occurs.



General description of dispenser

- Dispensers in the **UNICA (4/R - 8/R)** series are able to preserve bottles of wine, control their temperature (in chilled models only) and preserve, by means of an inert food-grade gas, their contents in order to serve only the desired quantities directly in a glass.
- The gas protects the wine against alterations caused by oxygenation and preserves its characteristics for up to 4 weeks after the bottle is opened.
- The dispenser has been designed to preserve and dispense the following types of still wine: dry, semi-dry, semi-sweet and sweet.
- The user of the dispenser can select one of the available wines and dispense the requested dose (small, medium, large).
- The dispenser is installed in commercial type environments (wine shops, wine bars, etc.).
- The dispenser can be produced in different models, differentiated by their type of construction and size (See “Technical data”).
- The dispenser can be used in different ways.
 - “Backdesk” mode: wine dispensing always enabled.
 - “Winecard” mode: wine dispensing enabled through a user’s electronic card.

NOTE: Do not use the dispenser with sparkling wine.

- See section “Routine maintenance schedule” for the regularity of dispenser cleaning in accordance with the sugar content of the wines.

NOTE: The dispenser is delivered in the “Backdesk” version. The “Winecard” version can be initialised during installation.

- The installed management software allows programming to offer personalised management and exclusive service.



4/R



8/R

46200906200

Description of main parts

The illustration shows the main components and the list provides a description and their function.

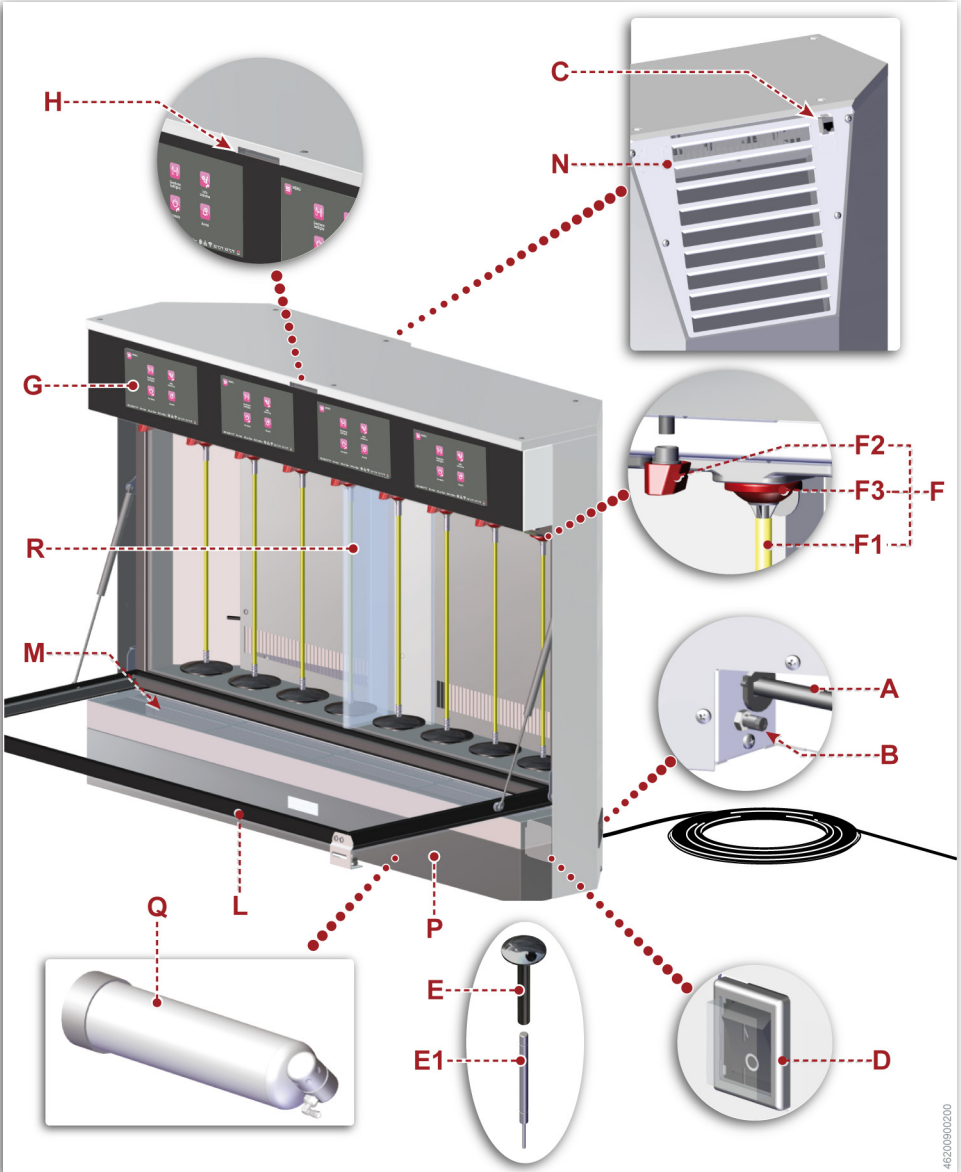

4620090200

- A) **Electrical power cord**
- B) **Inert gas connection**
- C) **LAN Ethernet (RJ-45) network port**
- D) **Electric switch (general)**
- E) **Bottle support:** activated by a gas spring **E1** to adapt to the height of the inserted bottle and hold it in position.
- F) **Dispenser:** composed of a bottle neck coupling, wine straw **F1**, pour spout cap **F2** and plug tap seal **F3**.
 - The bottle neck coupling is made in such a way as to ensure the gas pressure is held.
- G) **Display:** shows information concerning the operating status of the dispenser.
- H) **Electronic card reader**
- L) **Inverse flap door**
- M) **Drip tray**
- N) **Refrigeration unit ventilation grill**

- The refrigeration unit is electronically managed to adjust the temperature to the set operating value.
- The device is developed with a reciprocating hermetic compressor.
- Condenser cooling is obtained through electric fans.

P) Inert gas cylinder compartment

Q) Internal cylinder feeding system: feeds the wine dispensing circuit. (optional)

NOTE: The dispenser can be supplied with Argon (E938) or Nitrogen (E941).

 **Important**

Use only one gas source, either external or internal, to feed the dispenser.

R) Bottle compartment divider (for model UNICA 8/R only).

Description of cards

The dispenser is supplied with different types of cards having specific functions.

- A) **Start Up Card:** to activate the dispenser and access specific functions such as the creation of a User Card (winecard).
- B) **Manager Card:** to manage all dispenser functions.
- C) **Staff Card:** to manage only maintenance and bottle management functions.



Description of display (for backdesk)

“Backdesk” option view.

- A) **Field:** displays the dispensing instructions.
- B) **Field:** displays the dispensing keys for each dose.
 - B1) Small dose
 - B2) Medium dose
 - B3) Large dose
- C) **Field:** displays the name of the venue where the dispenser is installed.
- D) **Field:** displays the dispenser name.
- E) **Icon:** indicates that there are active warnings or alarm conditions.

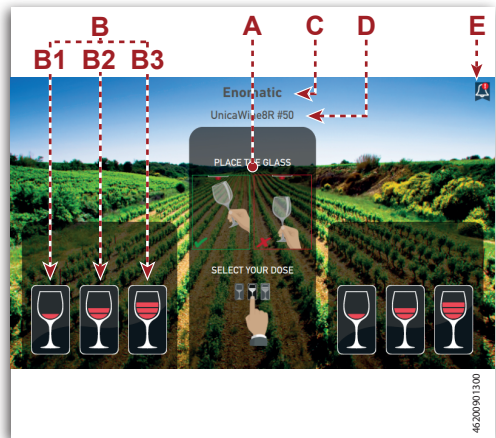

Description of display (for winecard)

“Winecard” option view.

A) **Field:** views the dispensing instructions.

B) **Field:** displays the dispensing keys for each dose.

B1) Small dose

B2) Medium dose

B3) Large dose

C) **Field:** displays the price of the corresponding dose.

D) **Field:** displays the residual credit in the user’s card.

E) **Field:** displays the name of the venue where the dispenser is installed.

F) **Field:** displays the dispenser name.

G) **Field:** displays information about the wine.

- Producer
- Production area
- Alcohol content of wine
- Type of grapes comprising the wine
- Bottle price

NOTE: There may also be icons identifying featured and/or organic wines.

H) **Icon:** indicates that there are active warnings or alarm conditions.

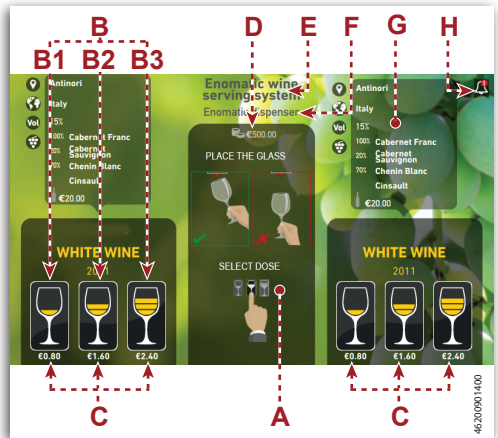

Description of display (Card Generator)

“Winocard” generation option view.

! Important

Using the Card Generator Software installed in the dispenser, it is possible to generate **ONLY** prepaid type cards.

A) Numeric keypad

B) **Drop-down menu:** to select which operation to perform.

- **Add:** to add credit to an existing “Winocard”.
- **Overwrite:** to update the “Winocard” credit.

C) **Field:** to programme the number of “Winecards” to generate.

D) **Field:** to programme the “Winocard” credit.

E) **Field:** to programme the number of days for which the “Winocard” is valid.

F) **Key:** to confirm the inserted values.

G) **Key:** to exit the screen without saving changes.

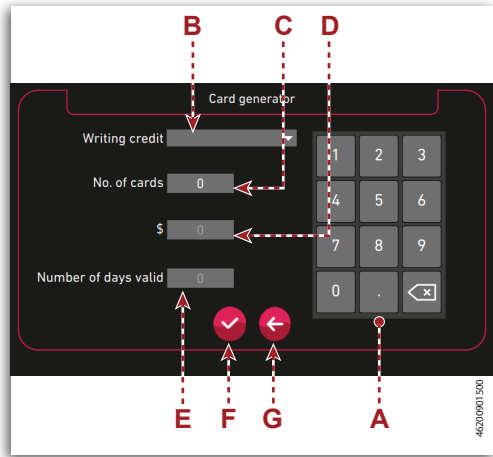

Description of display (Manager Card) (1)

“Manager Card” option view.

- A) **Field:** displays the current date and time.
- B) **Field:** displays the inbound pressure and the pouring pressure of the dispenser.
- C) **Icon:** indicates the status of the refrigeration system.
- C1) Refrigeration system enabled
- C2) Refrigeration system disabled
- C3) Refrigeration system active
- C4) Refrigeration system in “Defrost” mode
- C5) Door open (The refrigeration system is automatically deactivated when the door is open)
- D) **Icon:** signals that the LAN connection is active (if green it is also connected to the enosoft service)
- E) **Icon:** signals that the Wi-Fi connection is active (if green it is also connected to the enosoft service)
- F) **Field:** displays the set temperature.
- F1) **Field:** displays the derived temperature in the second compartment (For “UNICA 8/R” version only).
- G) **Icon:** indicates that there are active warnings or alarm conditions.

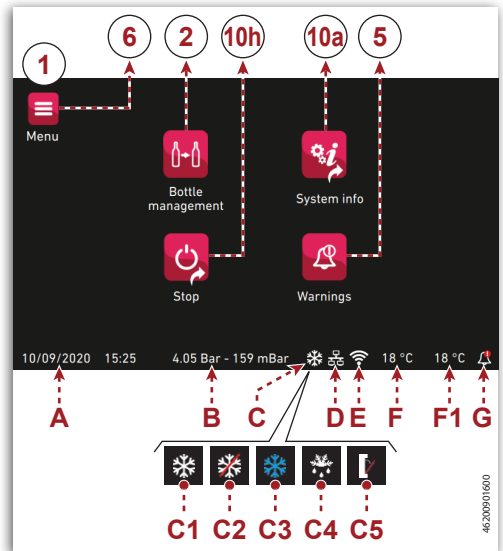

Description of display (Staff Card) (1a)

“Staff Card” option view.

- A) **Field:** displays the current date and time.
- B) **Field:** displays the inbound pressure and the pouring pressure of the dispenser.
- C) **Icon:** indicates the status of the refrigeration system.

- C1) Refrigeration system enabled
- C2) Refrigeration system disabled
- C3) Refrigeration system active
- C4) Refrigeration system in “Defrost” mode
- C5) Refrigeration system off and door open

D) **Field:** displays the real operating temperature.

D1) **Field:** displays the real operating temperature of the second compartment (For “UNICA 8/R” version only).

E) **Icon:** indicates that there are active warnings or alarm conditions.

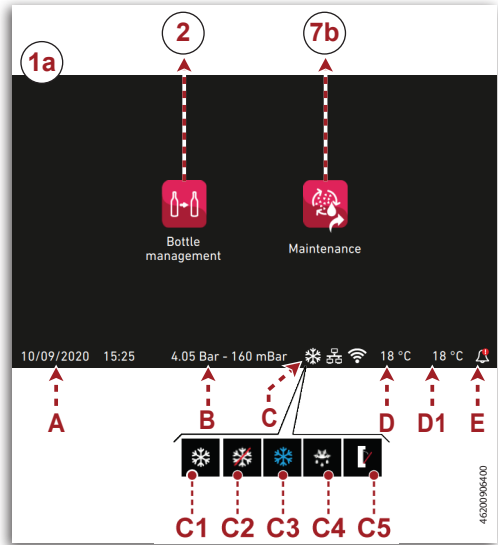

“Bottle management” screen (2)

Screen to insert new bottles and replace or remove empty ones.

- A) **Key:** to confirm the insertion of a bottle with the same details as the previous wine (For “Winecard” mode only).
- B) **Key:** to confirm the insertion of a new bottle.
- C) **Key:** to confirm the removal of a bottle (For “Winecard” mode only).

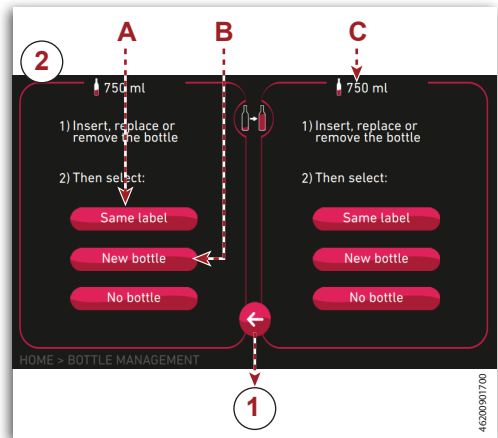

“Warnings” screen (5)

Screen to view information about the necessary maintenance procedures.

The table shows the operations to be carried out and relative time frames according to the colour.

Grey: no operation necessary.

Yellow: carry out later.

Red: carry out immediately.

A) **Key:** to view other warnings.

5

TYPE OF MAINTENANCE	DISPENSER GROUP NO.							
SANITISATION	1	2	3	4	5	6	7	8
CLEANING	1	2	3	4	5	6	7	8
CALIBRATION	1	2	3	4	5	6	7	8

No operation requested
 Carry out later
 Carry out immediately

Other warnings

HOME > WARNINGS

4/20/09/2000

A

1

“Menu” screen (6)

Screen to access programming of general operating parameters.

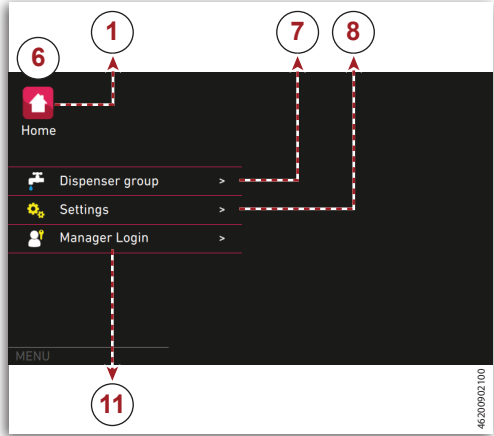

“Dispenser group” screen (7)

Screen to access programming of dispenser operating parameters.

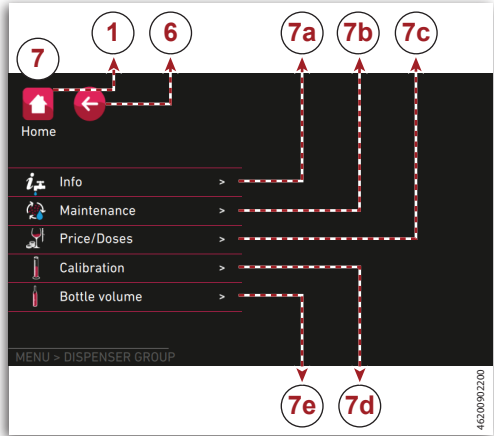

“Info” screen (7a)

Screen to view general information about the dispenser group.

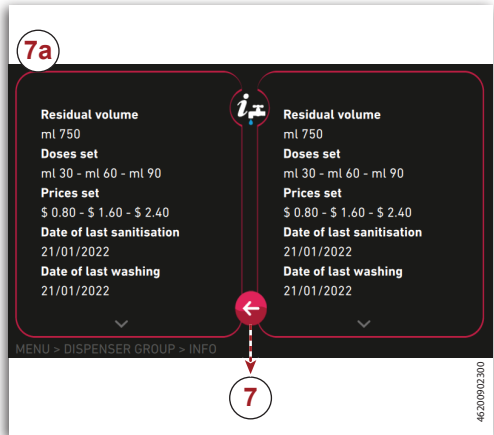

“Maintenance” screen (7b)

Screen to carry out maintenance works.

- A) **Key:** to carry out sanitisation (See “Dispenser sanitisation”).
- B) **Key:** to carry out cleaning (See “Dispenser cleaning”).
- C) **Key:** to carry out rinsing (See “Dispenser rinsing”).
- D) **Key:** to empty the dispenser duct (See “Dispenser emptying”).

NOTE: If the icon is shown next to the key, this indicates that the corresponding procedure is necessary.

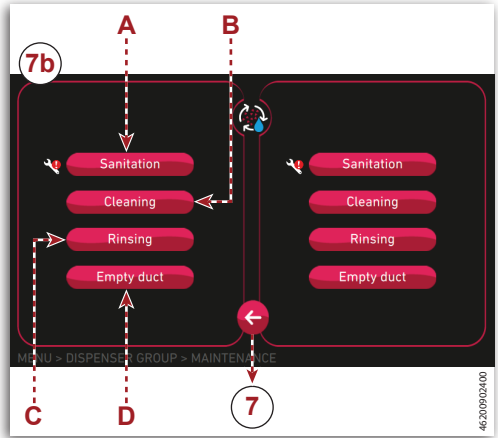

“Prices/Doses” screen (7c)

Screen to allocate prices and volumes to each dose (For “Backdesk” mode only).

- A) **Field:** to select to which dose the price must be allocated.
- B) **Field:** to programme the volume of the dose to be dispensed.
- C) **Field:** to programme the price of the dose to be dispensed.
- D) **Key:** to programme the same values in all dispensers.
- E) **Key:** to confirm the inserted values.

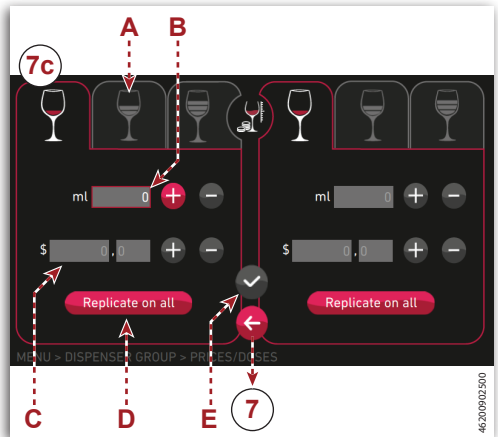

“Calibration” screen (7d)

Screen to calibrate the dispenser.

NOTE: This function can **ONLY** be accessed by personnel with a “Manager Card”.

- Calibration is normally carried out by the installer during the first start-up of the dispenser.
- A new calibration is needed when a total reset of the counters is carried out, or else after a technical intervention that requires calibration.
- The calibration procedure must be carried out with the usual wine or else a wine with similar density and viscosity, which will be inserted in the single station.
- To carry out the calibration, follow the instructions viewed on the display.

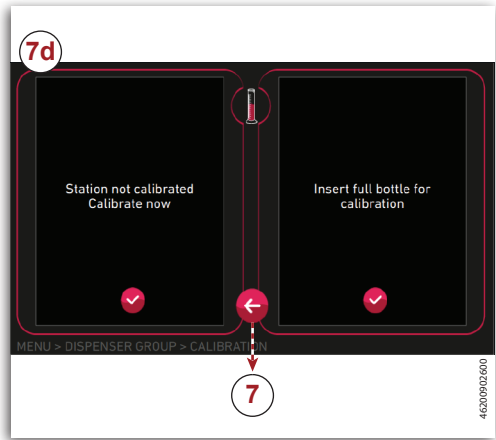

! Important

To measure the quantity dispensed during the calibration, a graduated cylinder must be used, which can be purchased from an ENOMATIC® retailer.

“Bottle volume” screen (7e)

Screen to programme the bottle volume (For “Backdesk” mode only).

- A) **Field:** to select the bottle type.
- B) **Field:** to manually programme the bottle volume.
- C) **Key:** to programme the same values in all dispensers.
- D) **Key:** to confirm the inserted values.

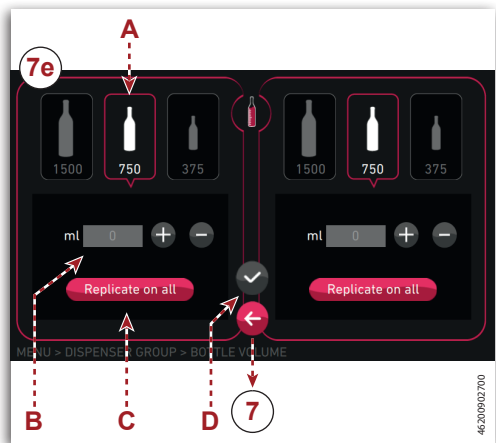

“Settings” screen (8)

Screen to access general programming of the dispenser.

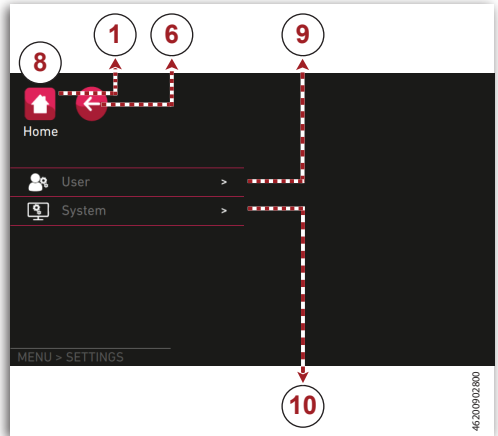

“User” screen (9)

Screen to access programming of the viewing parameters (language, currency, etc.).

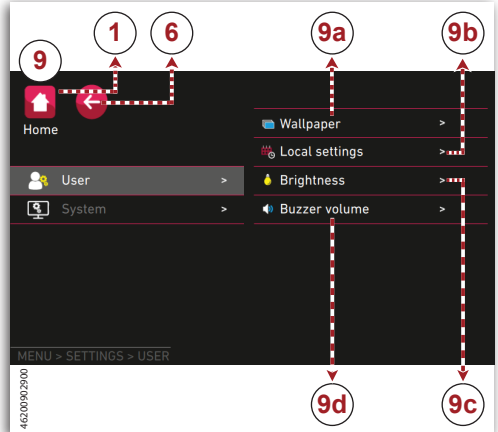

“Wallpaper” screen (9a)

Screen to select the wallpaper of the display.

A) Field: to select the wallpaper.

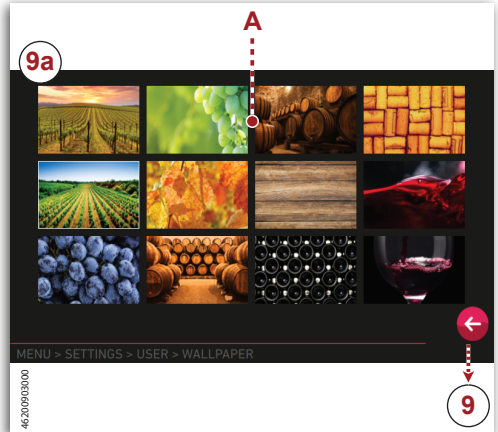

“Local settings” screen (9b)

Screen to programme the viewing parameters (language, currency, etc.).

NOTE: The screens are not visible in “EnoSoft” mode.

■ **Date/Time**

- A) **Field:** to programme the date.
- B) **Field:** to programme the date format.
- C) **Field:** to programme the time.
- D) **Key:** to programme the time format.
- E) **Key:** to confirm the inserted values.

NOTE: The screen is not visible in “EnoSoft” Enoservice connected mode.

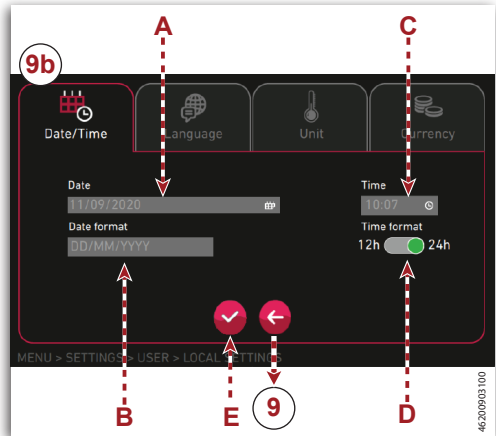

■ **Language**

- F) **Drop-down menu:** to select the viewing language.
- G) **Key:** to confirm the inserted values.

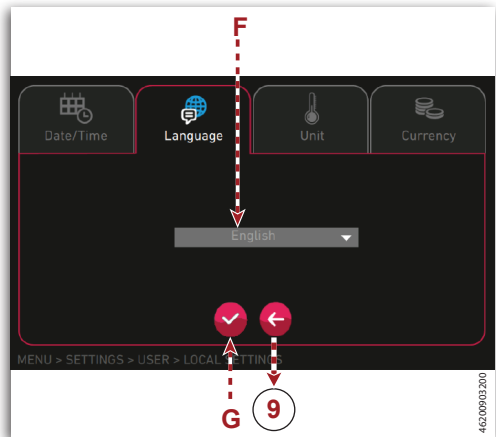

■ **Unit**

H1)**Drop-down menu:** to select the temperature unit.

H2)**Drop-down menu:** to select the volume unit.

L) **Key:** to confirm the inserted values.

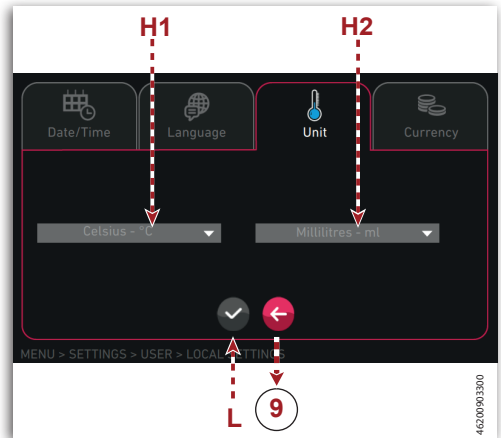

■ **Currency**

M)**Drop-down menu:** to select the currency.

N) **Key:** to confirm the inserted values.

NOTE: The screen is not visible in “EnoSoft” Enoservice connected mode.

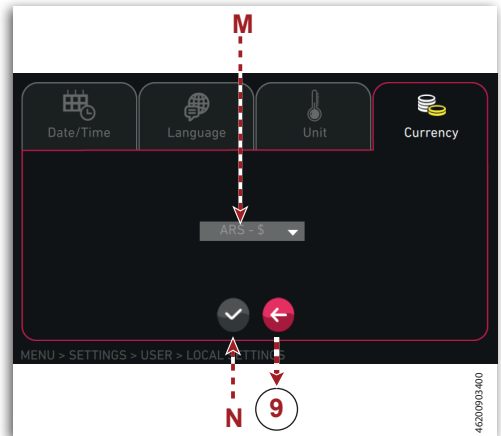

“Brightness” screen (9c)

Screen to programme the brightness in various areas of the dispenser.

- A) **Key:** to enable the energy saving mode (after 1 hour of non-use the display brightness is reduced to the minimum level).
- B) **Field:** to programme the brightness in the various areas of the dispenser.
- C) **Key:** to confirm the inserted values.

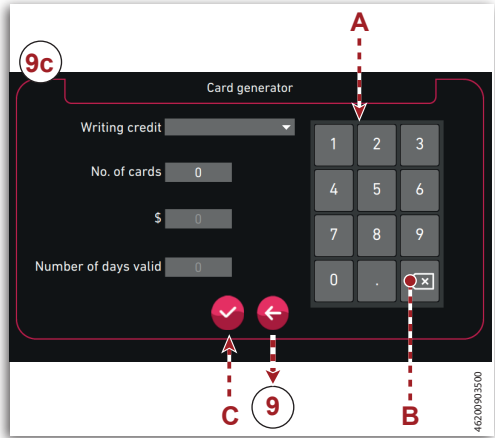

“Buzzer volume” screen (9d)

Screen to programme the buzzer volume.

- A) **Field:** to programme the buzzer volume.
- B) **Key:** to confirm the inserted values.

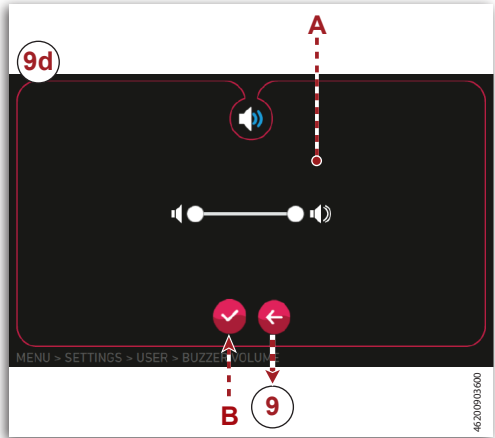

“System” screen (10)

Screen to access general programming of the dispenser.

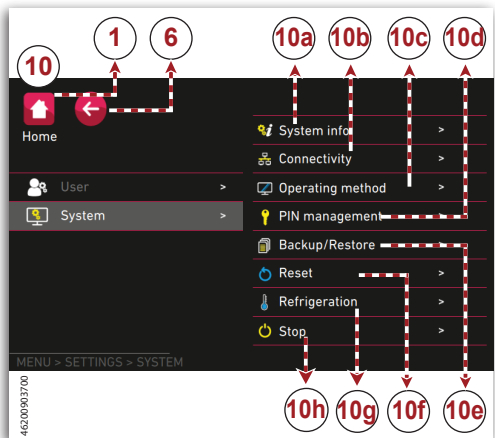

“System info” screen (10a)

Screen to view general information.

A) **Key:** to view supplementary information.

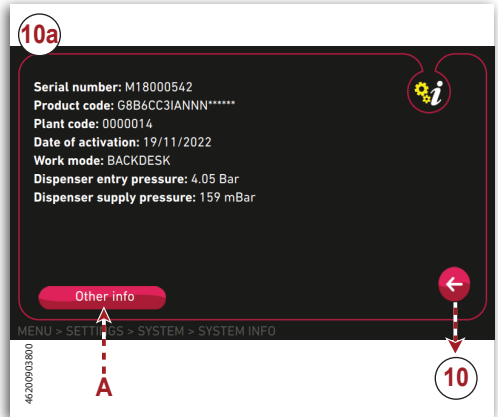

“Connectivity” screen (10b)

Screen to connect the dispenser to the internet.

■ **Ethernet**

– To connect to the local wired network via Ethernet cable.

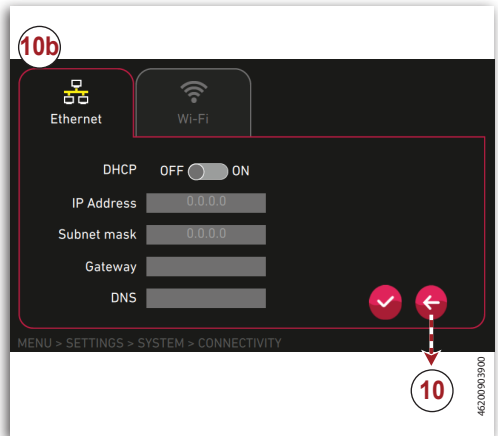

■ **Wi-Fi**

– To connect to the local network via Wi-Fi.

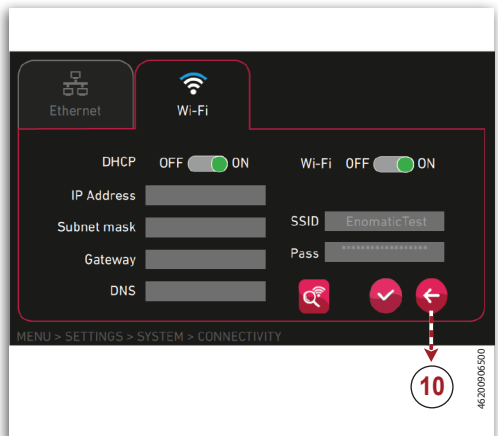

“Operating method” screen (10c)

Screen to configure the operating method of the dispenser.

■ Working mode

A) **Key**: to enable the “Winecard” function.

B) **Drop-down menu**: to select the working mode.

– WINE CARD “ON”

- Enoservice: to manage the Dispenser and create “Winecards” through the “EnoSoft” software.

- Card Generator: To manage the Dispenser and create “Winecards” directly from the latter.

– WINE CARD “OFF”

- Backdesk: to enable the “Backdesk” use mode with anonymous wines.

- Backdesk plus: to enable the “Backdesk” use mode with details of the wines.

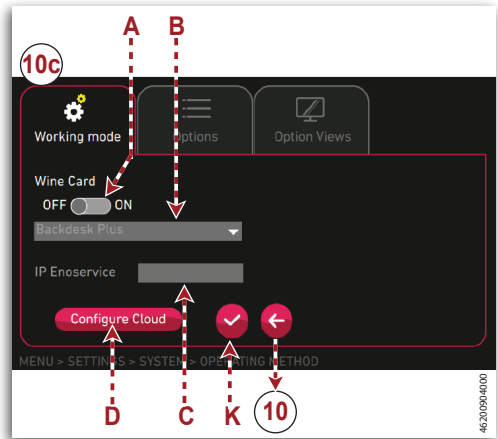

C) **Field**: to insert the IP address of the computer for remote control of the dispenser.

D) **Key**: for cloud configuration.

NOTE: Reserved to the Technical Help Service or manufacturer’s authorised personnel.

K) **Key**: to confirm the inserted values.

⚠ Important

Depending on the selected work mode, certain functions may be blocked or modifiable.

■ Options

- E) **Field:** to enable the dispenser for product pouring.
- F) **Field:** to enable the cloud connection.
- G) **Field:** to enable the RFID card reader.
- H) **Field:** to enable the dispensing procedure based on the residual credit of the user card.
- K) **Key:** to confirm the inserted values.
- L) **Field:** to enable the bottle change function with another of the same type.
- N) **Field:** to enable the Screen Saver.
- P) **Field:** to enable protection against non-enabled cards.

NOTE: The protection function is only active with the dispenser connected in remote to an external computer with “EnoSoft” software, by enabling the “Software card Control” option.

- Q) **Field:** to enable dispensing in “Backdesk” mode, only after having inserted the card of the person in charge of the dispenser.

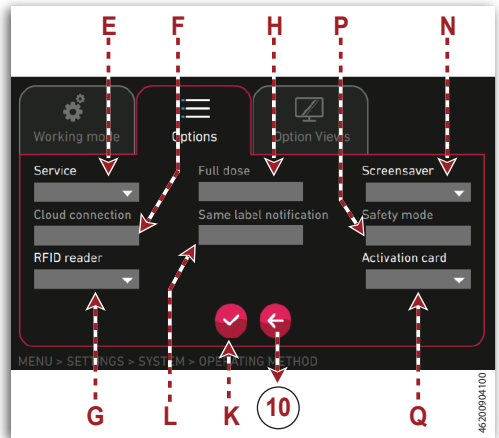

■ **Option views**

- K) Key:** to confirm the inserted values.
- R) Field:** to programme the dispenser name.
- S) Field:** to enable viewing of the product information during dispensing.
- T) Field:** to enable viewing of the bottle price.
- U) Field:** to enable viewing of the residual product volume during dispensing.
- V) Field:** to enable viewing of the dose volume during dispensing.
- Z) Field:** to enable viewing of the currency during dispensing.

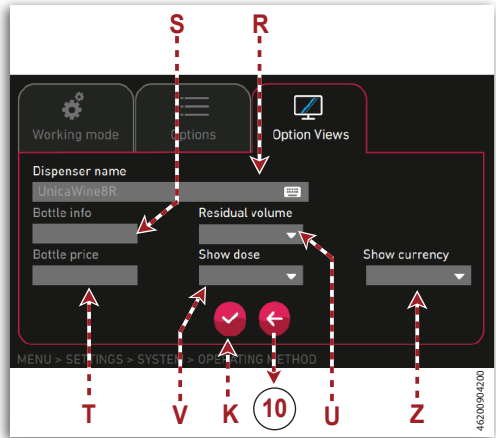

■ **Configure Cloud**

- K) Key:** to confirm the inserted values.
- W) Field:** to insert the user name to be connected.
- X) Field:** to insert the password.
- Y) Key:** to run the connection test.

⚠ Important

The credentials are those used to access the reserved area on the “enotecha” web portal. Each time the password for the “enotecha” portal is changed, it must also be updated in the dispenser.

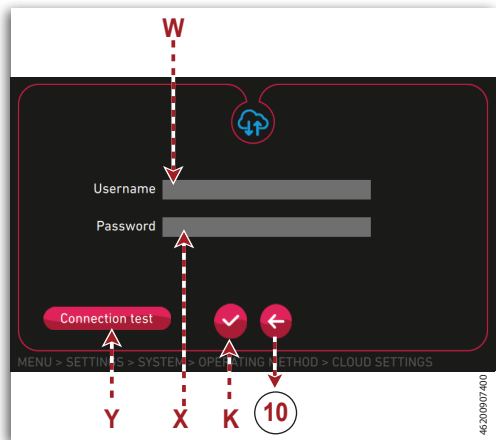

“PIN management” screen (10d)

Screen to change the password to access the protected functions.

- A) Numeric keypad
- B) Field: to insert the old password.
- C) Field: to insert the new password.
- D) Field: to confirm the new password.
- E) Key: to confirm the inserted values.
- F) Key: to restore the default values.

NOTE: The Default PIN corresponds to the plant code communicated to the client when the dispenser was activated.

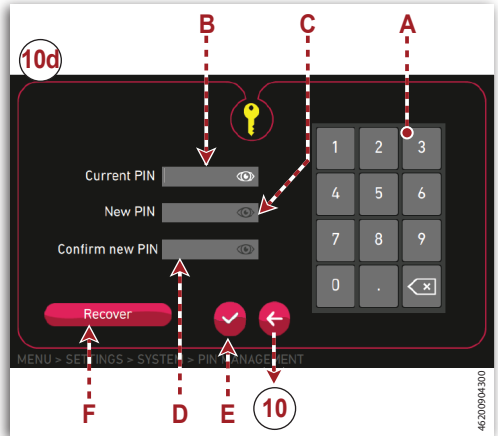

“Backup/Restore” screen (10e)

Screen to programme the backup and recovery of the Software.

- A) Key: to enable automatic backup on an external storage device.
- B) Field: to programme the time of the automatic backup.
- C) Key: to run the backup on a storage device.
- D) Key: to recover the configuration parameters from a storage device.
- E) Key: to confirm the inserted values.

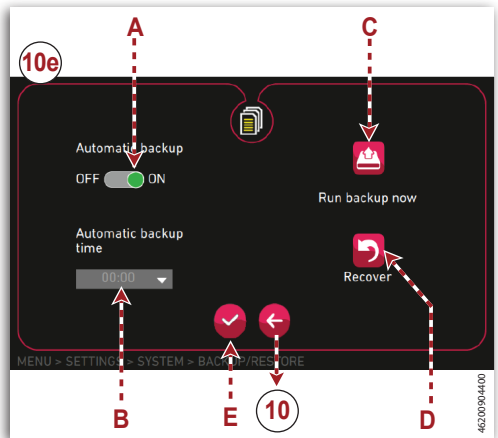

“Reset” screen (10f)

Screen to reset the operating parameters.

- A) **Key:** to reset all the counter data.
- B) **Key:** to reset all the partial counter data.

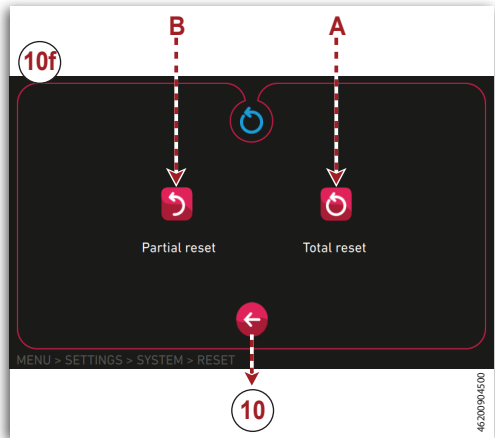

“Refrigeration” screen (10g)

Screen to programme the refrigeration parameters.

■ **General**

- A) **Key:** to enable the automatic defrost function.
- B) **Field:** to programme the time of the automatic defrost.
- C) **Key:** to activate the defrost function.
- D) **Key:** to enable the refrigeration function.
- E) **Key:** to enable the operating mode for the hot/humid zones.
- F) **Key:** to confirm the inserted values.

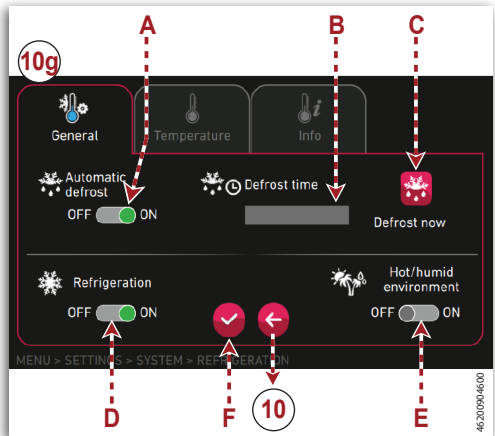

■ **Temperature**

G) **Field:** to program the temperature of the bottle compartment or left bottle compartment.

G1) **Field:** to program the temperature in the right side. (For model Unica 8/r only).

I) **Key:** to program use with or without the separator for control with respectively two or one temperature/s. (For model Unica 8/r only).

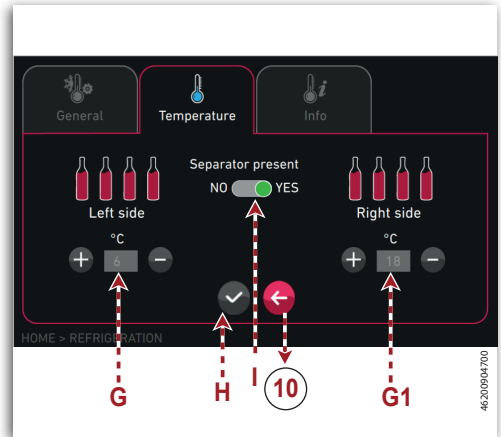

NOTE (For model Unica 8/r only) :
The minimum settable temperature in the right side is 12°C (54°F) when the temperature of the left side is 6°C (43°F).

The minimum temperature of the right side is proportional to the temperature set in the left side and follows the rule in the tables below.

Left-side temperature setting °C	Right-side minimum corresponding temperature °C
6	12
7	12
8	12
9	13
10	14
11	15
12	16
13	17
14	18
15	18
16	18
17	18
18	18

Left-side temperature setting °F	Right-side minimum corresponding temperature °F
43	54
44	54
45	54
46	54
47	54
48	55
49	56
50	57
51	58
52	59
53	60
54	61
55	62
56	63
57	64
58	64
59	64
60	64
61	64
62	64
63	64
64	64

■ Info

L) **Field:** to view information about the operation of the dispenser.

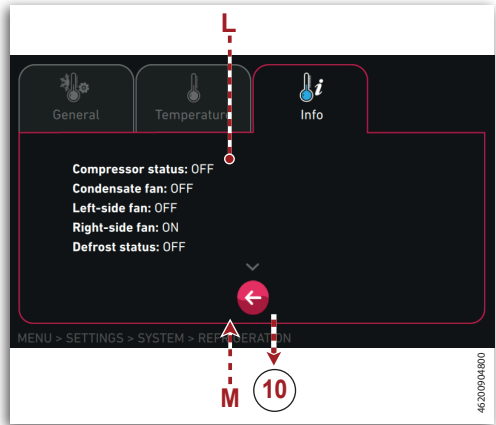

“Stop” screen (10h)

Screen to reboot or stop the dispenser.

A) **Key:** to stop the dispenser.

NOTE: With the dispenser off the electronic card reader remains lit.

B) **Key:** to reboot the dispenser.

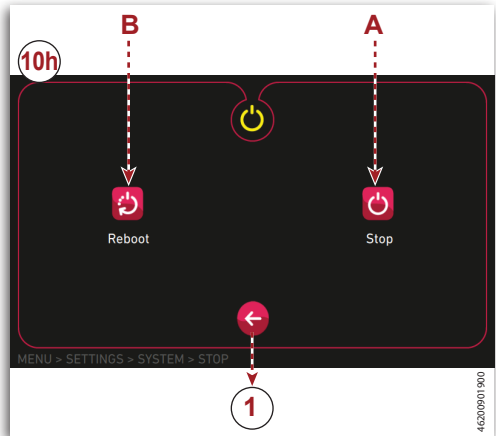

“Manager login” screen (11)

Screen to enable access to the protected functions.

- A) **Numeric keypad**
- B) **Field:** to insert the password.
- C) **Key:** to confirm the inserted values.

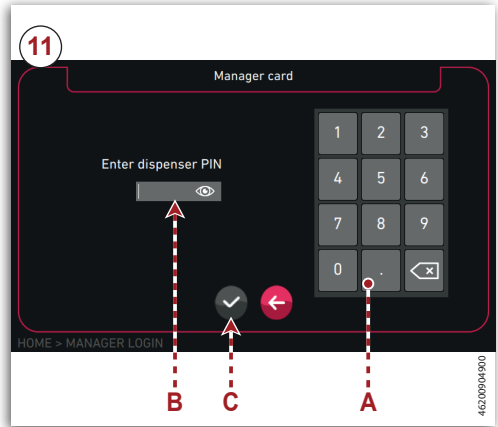

Management of dispenser from remote devices (S3App)

Control functions can be managed from remote devices through a browser (For “Backdesk plus” or “Card Generator” mode only).

- Essential requisites for connection to browser.
 - The dispenser and remote control device must necessarily be connected to the same local network.
 - Certified browsers must be used for the connection.
 - To connect the dispenser, open the browser and type in the IP address of the dispenser in the address bar.

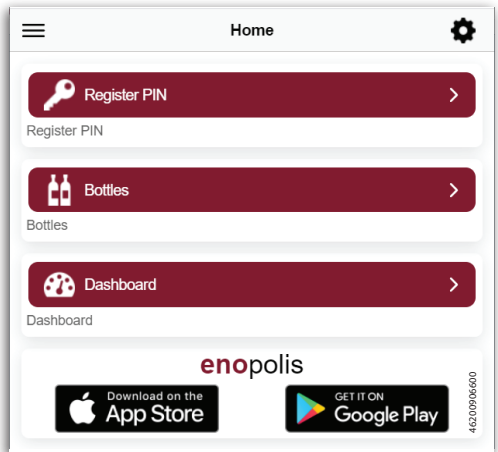

Technical data

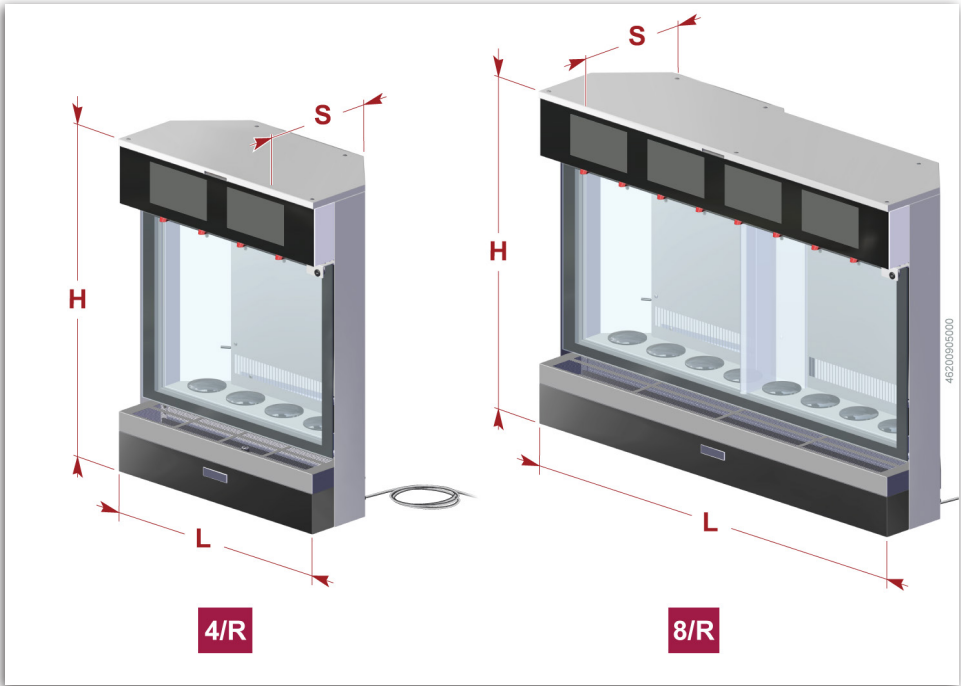
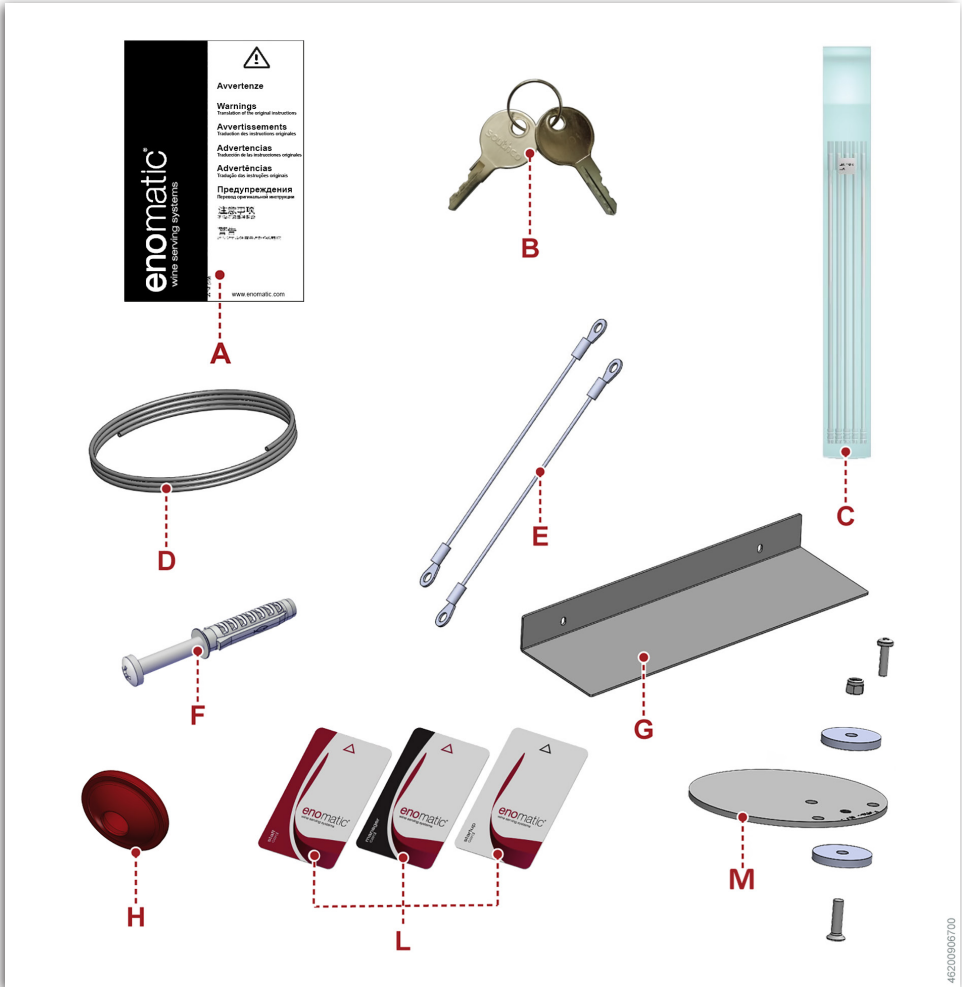

Table 1: Technical data

Description	Unit	Model	
		UNICA 4/R	UNICA 8/R
Sizes and weights			
Length L	in	20.91	37.44
Height H	in	27.72	27.72
Width S	in	12.48	12.48
Weight	lbs	81.57	126.77
Height of support surface	mm	900 ÷ 1000	900 ÷ 1000
Dispenser characteristics			
Number of bottles		4	8
Wine preservation temperature	°C (°F)	6 ÷ 18 (43 ÷ 64)	
Electrical characteristics			
Electric power input	kW	See attached "Technical Data Sheet"	
Electric current voltage	V		
Electric current frequency	Hz		
Electric current input	A		

Description	Unit	Model	
		UNICA 4/R	UNICA 8/R
Gas characteristics			
Type of feed gas	-	Argon, Nitrogen (Food Grade)	
Gas operating pressure for wine dispensing circuit	bar (Mpa)	4 ÷ 6 (0.4 ÷ 0.6)	
Air consumption (for each pour)	l/min	0.375	
Connection tube diameter O.D - I.D	mm	4- 2.5	
Refrigeration system characteristics			
Type of refrigerant gas	-	R134a	
Quantity of refrigerant gas	gr (oz)	80 (2.82)	
Duration of defrost cycle	min	20	
Settable temperature	°C (°F)	6 ÷ 18 (43 ÷64)	6 ÷ 18 (43 ÷64)
Right-side settable temperature	°C (°F)	-	12 ÷18 (54 ÷64)
Bottle characteristics			
Height (step 1)	mm	220 + 342	
Height (step 2)	mm	231.5 + 353.5	
Height (step 3)	mm	243 + 365	
Maximum diameter	mm	105	
Maximum diameter (Bottles adherent to separator).	mm	89	
Preset bottle volume	ml	375 - 750 - 1500	
Settable bottle volume	ml	0 + 1500	
Settable dose volume	ml	0 + 1500	
Ambient conditions			
Relative humidity (measured at a temperature between 16°C and 32°C inclusive)	-	60%	
Ambient operating temperature	°C (°F)	16 + 32 (60 + 90)	
Maximum noise level (1 m)	dB(A)	35	
Packaging dimensions			
Length L	mm	606	1026
Height H	mm	816	816
Width S	mm	414	414
Weight	kg	37	57.4
Storage conditions			
Storage temperature	°C (°F)	0 + 40 (32 + 104)	
Maximum storage humidity	-	65%	

Standard accessories



The listed accessories are supplied standard with the dispenser.

- A) n. 1 Instruction handbook
- B) n. 2 Pairs of keys for the door lock / cylinder compartment protection lock
- C) n. 1 Set of wine straws (2 sets for the "UNICA 8/R" version)
- D) n. 1 Food-grade LLDPE tube for feed gas connection Ø4x2.5mm / 3m
- E) n. 2 Steel cables
- F) Fasteners
- G) n. 1 Rear fixing bracket
- H) n. 1 Rounded seal
- L) n. 1 Cards Set (1 Manager Card, 1 Staff Card, 2 Start Up Card)
- M) no.2 Anti-tip feet with screws

Packing and unpacking

- The dispenser is packed in a dedicated container with the external surfaces properly protected with film.
- During unpacking, carefully extract the dispenser and check the integrity of its components.
- Wear suitable personal protective equipment (gloves and shoes) to avoid the risk of abrasion and/or crushing.
- In case of damage or missing parts, do not use the dispenser, rather contact your vendor to arrange for the relevant procedure to be adopted.
- The package contains all the necessary information for correct handling.
- The packing material must be properly disposed of in compliance with laws in force.
- If necessary, keep the packaging material for subsequent packing.

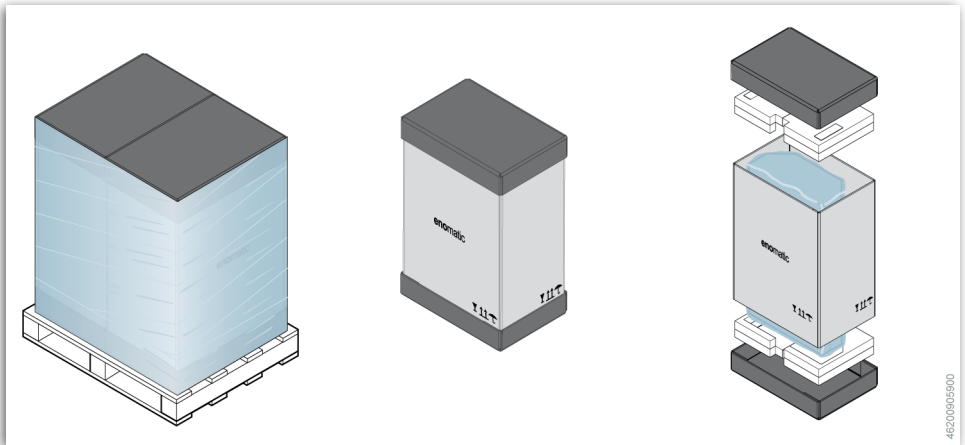

Transportation and storage

- Transportation, also depending on the destination, can be carried out using different means.
- The diagram shows the most common solutions for transportation and lifting.
- The dispenser is delivered in suitable packaging to protect it during transportation.
- Transportation must be carried out with the package in the vertical position, as indicated by the symbols applied directly thereon.

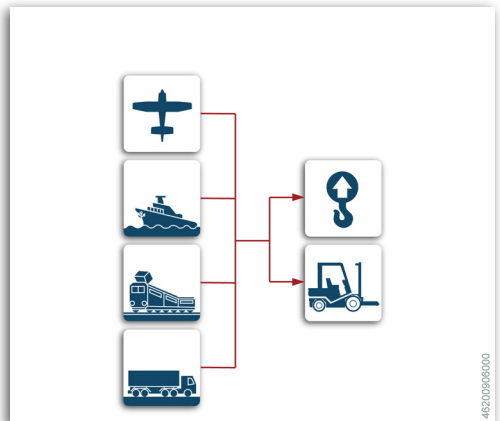

- The package contains all the necessary information for correct handling.
- During handling, handle the package carefully and avoid overturning as this could damage the dispenser.
- If the dispenser is not immediately installed upon receipt, but rather must be stored for a long period of time, it must be placed in a suitably dry and protected environment (See "Technical data").

Handling and lifting

- The dispenser can be handled using fork-based or hook-based lifting means of a suitable capacity.
- Before lifting, check the position of the barycentre of the load.
- The illustrations show the most common lifting and handling procedures.

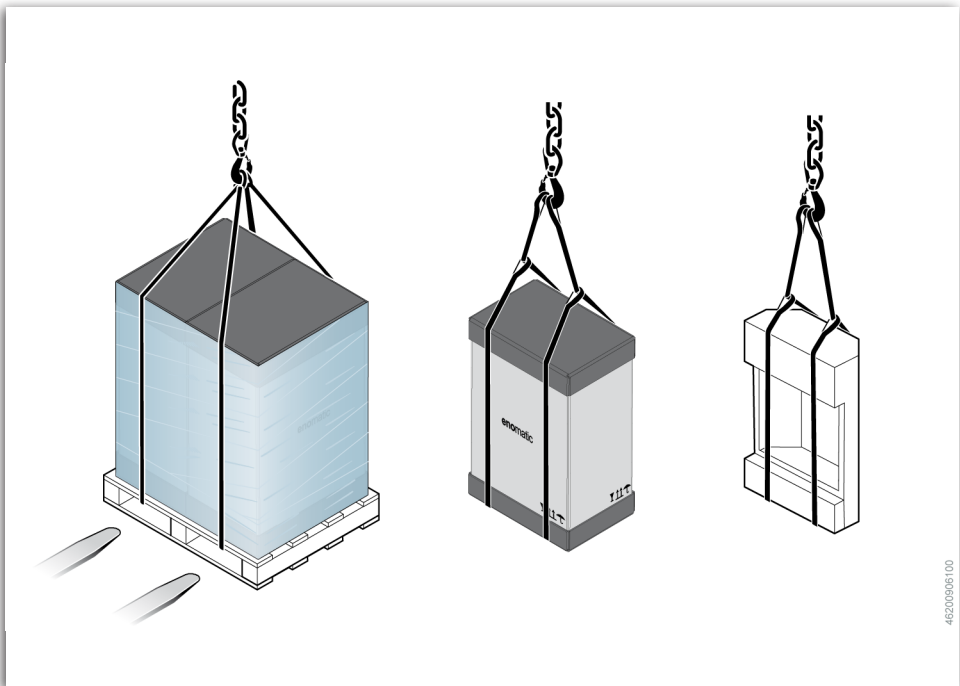

Inspection of “packing list” and integrity of dispenser

- Each shipment is accompanied by a document containing a list and description of the different packages.
- Upon receipt of the packages, check that the Packing List effectively corresponds to the received material and that

the packages are perfectly intact.

In case of damage or missing parts do not use the dispenser, rather contact your vendor to arrange for the relevant procedure to be adopted.

Recommendations for installation and connection

The installation, connections and fine tuning of the dispenser must be carried out only by the manufacturer’s authorised technicians.

- Before installation, the technician must evaluate the most suitable location in which to position the dispenser.
- The technician must make sure the space intended for the installation and storage of the cylinders (food-grade argon/nitrogen) is suitable for said purpose.

- Wear suitable personal protective equipment (gloves and shoes) to avoid the risk of abrasion and/or crushing.
- Before making the electrical connection, check that the system complies with legislation in force and that its characteristics correspond to those indicated on the data plate.

Installation and connection

Proceed as indicated.

1. Keep the dispenser in the installation position for at least 12 hours so as not to damage the refrigeration system.
2. Position the dispenser in the intended area according to the attached technical data sheet.

 **Important**

If the Dispenser has not been adequately transported or handled in respect of the position indicated on the packaging, contact the help service before its commissioning.

3. Secure the dispenser in one of the intended configurations following the technical data sheet
 - With anti-tip tie-rods
 - With fasteners
 - With anti-tip feet

NOTE: For specific information concerning the fastening procedures, see the attached technical data sheet.

4. Set up the gas feed system according to the intended installation type (with gas cylinder, with gas generator, etc.).

NOTE: Gas cylinders and regulator are not supplied with the dispenser.

NOTE: For details of the minimum dimensions of the ventilation ducts, see the attached technical data sheet.

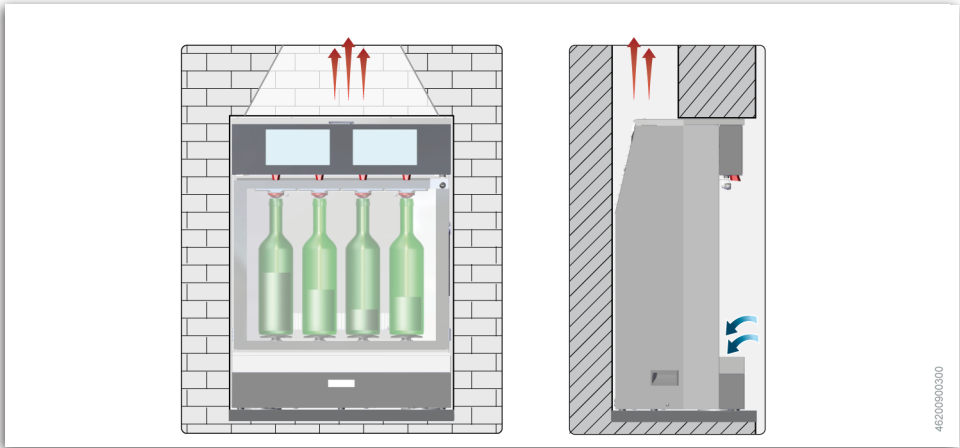

– Installation with ventilation duct

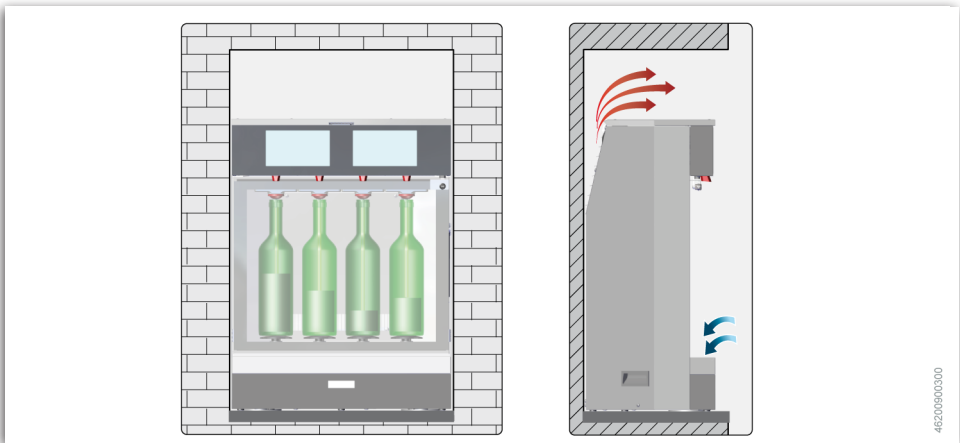

– Installation without ventilation duct

■ **Gas connection (with external cylinder)**

- The illustration shows various examples of the gas feed system with one or more dispensers.

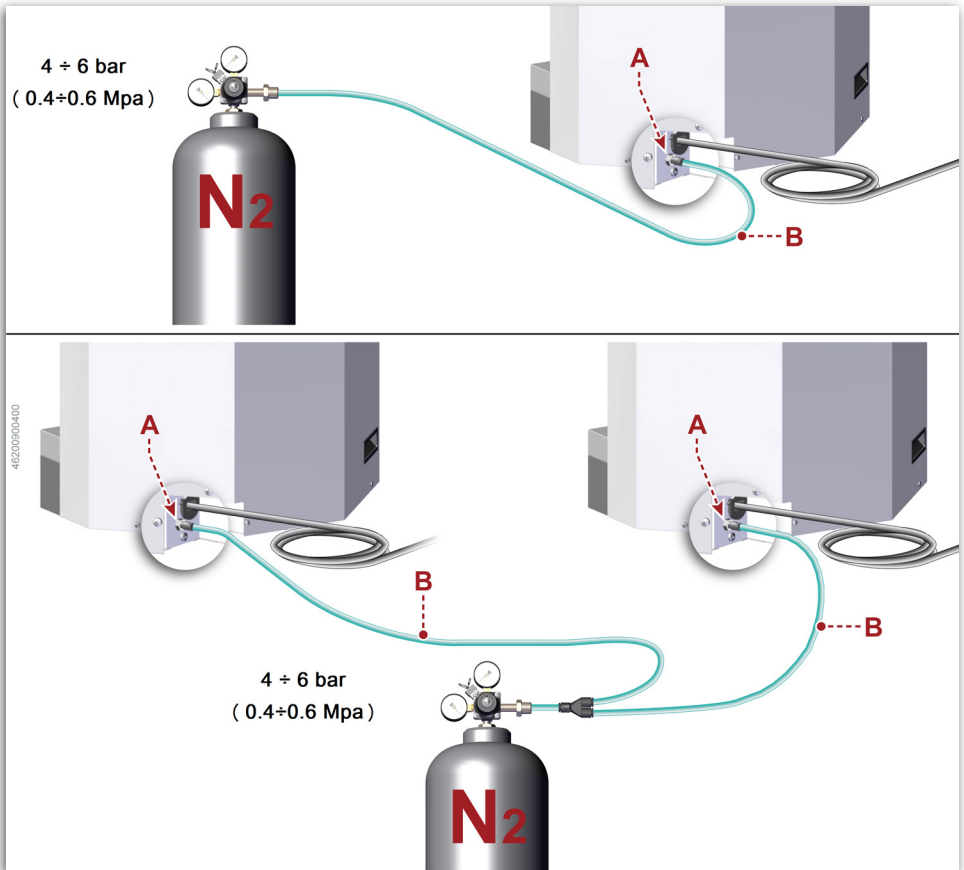

5. Check that the gas bypass tube is properly installed in the dispenser compartment (See "Description of main parts").
6. Unscrew the ring nut **A**.
7. Insert the ring nut **A** in the gas feed tube **B**.
8. Connect the gas feed tube **B** to the dispenser socket.
9. Screw the ring nut **A** back on.

⚠ Important
DO NOT use a wrench to tighten the ring nut.

⚠ Important
Use only Food-grade Gases such as Argon (E938) or Nitrogen (E941).

■ Gas connection (with internal cylinder)

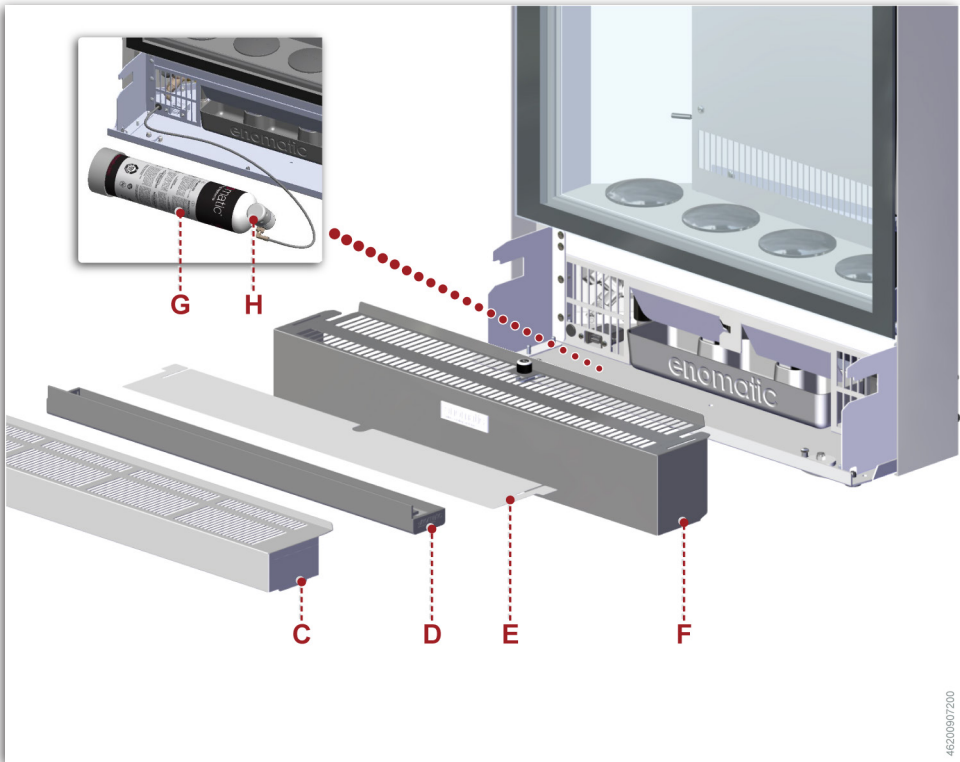

10. Remove the grate **C**.
11. Remove the drip tray **D**.
12. Dismantle the filter **E**.
13. Release the protection **F**, using the key, and remove it.
14. Position the cylinder **G** and connect it to the dispenser.
15. Operate the tap **H** to adjust the gas pressure.

- The operating pressure is 4 bar
16. Assemble the protection **F** and block it with the key.
 17. Assemble the filter **E**.
 18. Assemble the drip tray **D**.
 19. Assemble the grate **C**.

⚠ Important
Use only Food-grade Gases such as Argon (E938) or Nitrogen (E941).

■ Electrical connection



20. Connect the plug **L** to the socket **M**.

NOTE: Before connecting the plug to the mains, check that the switch is in the **OFF** position and that the electrical characteristics correspond to those reported on the data plate.

21. Perform a general inspection to check that the dispenser is working properly and check that there are no fluid leaks (air, gas, etc.).

22. Connect the Ethernet network cable **N** to the socket **P** of the dispenser.

NOTE: The Ethernet network cable must be category “6E”.

23. Initialise the dispenser.

 **Important**

The dispenser must be initialised by the manufacturer’s authorised personnel.

Dispenser start and stop procedures

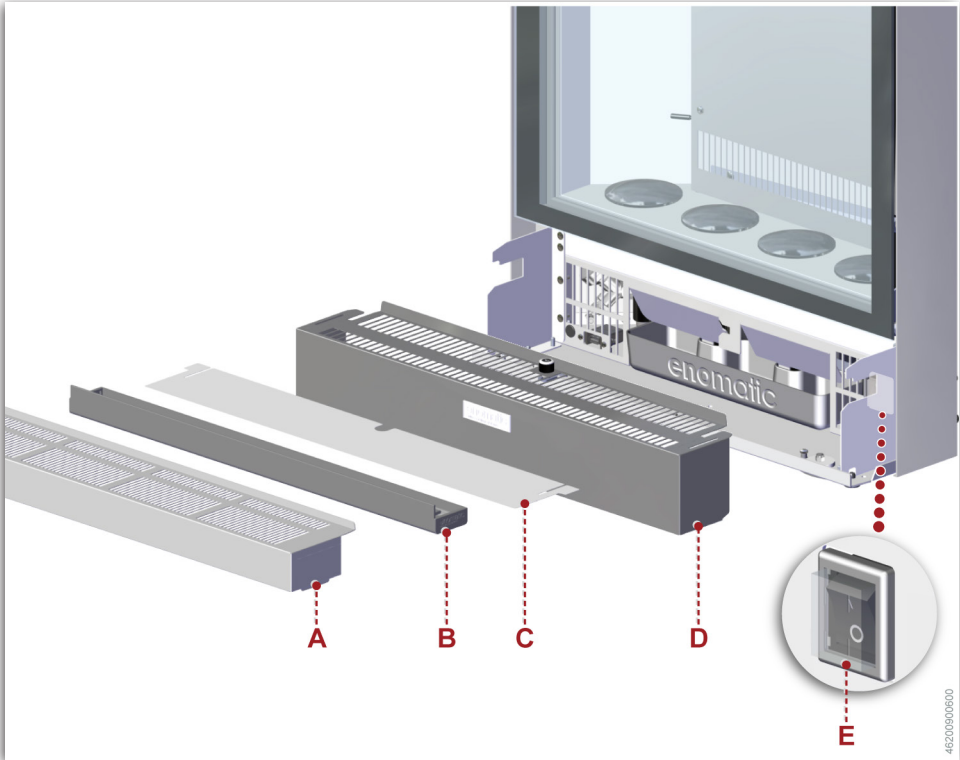

■ Start

– Proceed as indicated.

1. Check that the electrical plug is inserted.
2. Remove the grate **A**.
3. Remove the drip tray **B**.
4. Dismantle the filter **C**.
5. Release the protection **D**, using the key, and remove it.
6. Press the switch **E** in position “I” (ON) to activate the general power supply.

The dispenser will run a quick operating check-up and the displays will turn on.

7. Assemble the protection **D** and block it with the key.
8. Assemble the filter **C**.
9. Assemble the drip tray **B**.
10. Assemble the grate **A**.
11. Activate the gas feed system and check that the operating pressure is correct.

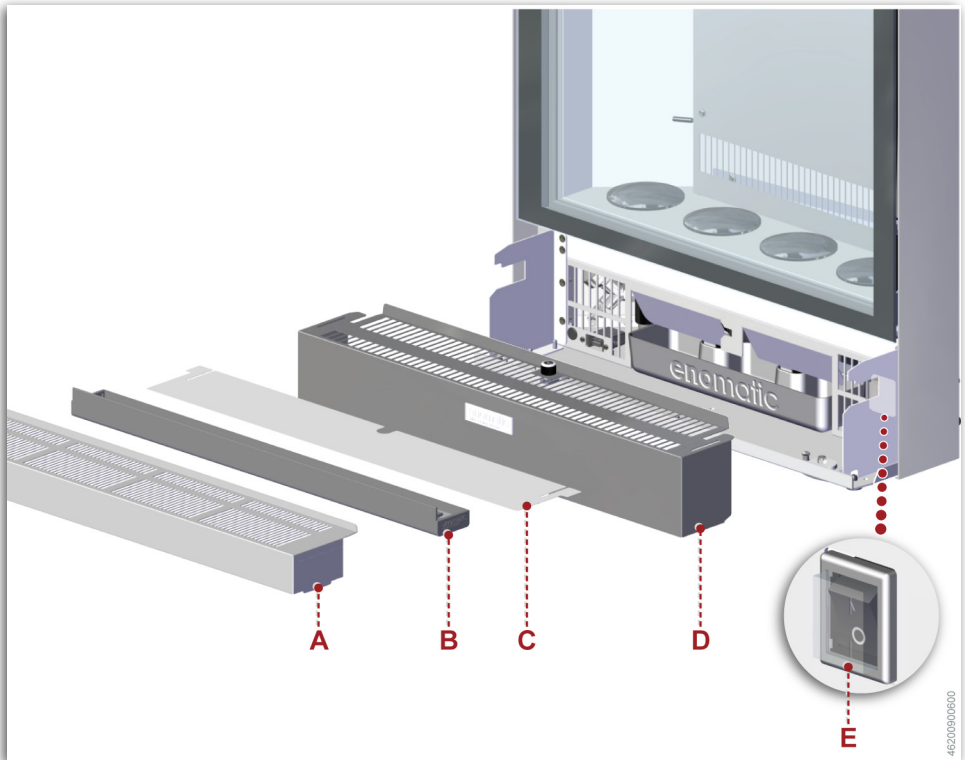

■ **Stop**

Proceed as indicated.

1. Deactivate the gas feed system.
2. Remove the grate **A**.
3. Remove the drip tray **B**.
4. Dismantle the filter **C**.
5. Release the protection **D**, using the key, and remove it.
6. Press the switch **E** in position “O” (OFF).
7. Assemble the protection **D** and block it with the key.
8. Assemble the filter **C**.
9. Assemble the drip tray **B**.
10. Assemble the grate **A**.
11. Disconnect the plug from the electrical power socket.

NOTE: Before stopping the dispenser for long periods, remove all bottles and perform routine maintenance.

Preparation of wine straws

- The total length of the wine straws A must be about 2÷5 cm (0.79"÷1.97") longer than that of the bottle.
- straw too long: cut the excess part with scissors.
An excessively long straw may bend inside the bottle and limit or interrupt the flow of wine.
- straw too short: replace with a new one.
An excessively short straw might not allow all the wine in the bottle to be dispensed.

NOTE: Always replace any worn wine straws.

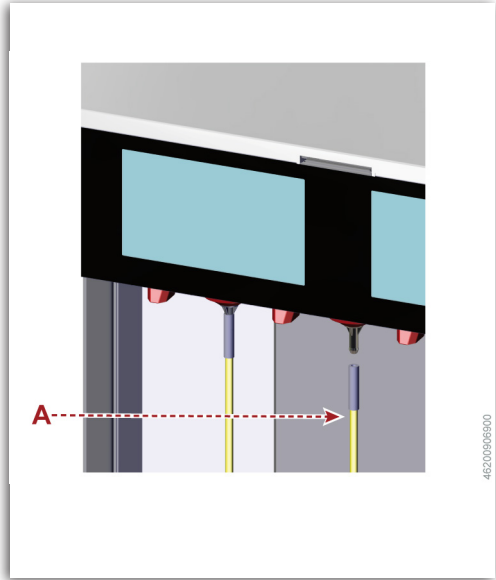

46Z0096900

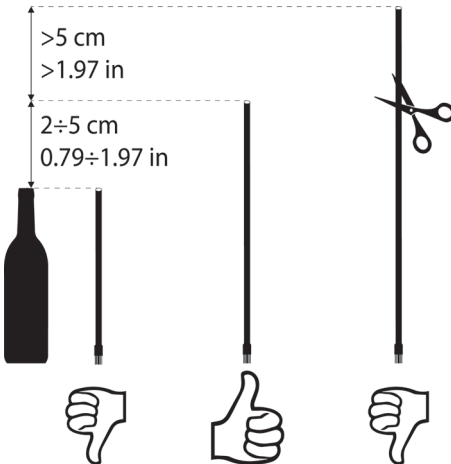

First bottle insertion

⚠ Important

NEVER use bottles that are not completely full so as not to alter the data counted by the dispenser.

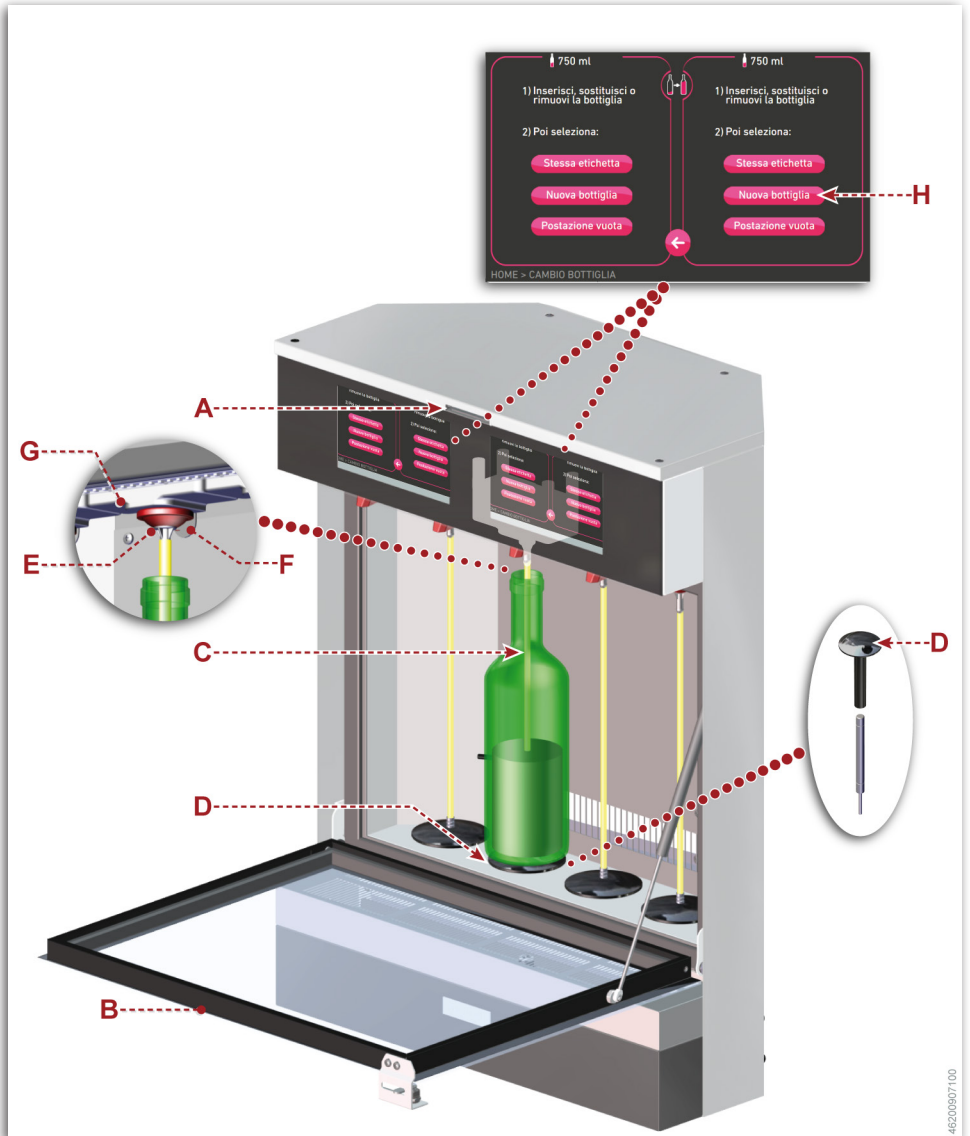

4620907100

Proceed as indicated.

1. Insert the “MANAGER” or “STAFF” card in the reader **A**.
2. Open the door **B**.
3. Thoroughly clean the bottle mouth of any residue and check that there are no rough edges to avoid microleaks.
4. Insert the wine straw **C** in the dispenser group (See “Preparation of wine straws”).
5. Insert the support **D**.
6. Push the support **D** until it is locked in the low position.
7. Uncork the bottle to be inserted in the dispenser.
8. Insert the wine straw **C** in the new bottle and position it on the support **D**.
9. Push the bottle to release the support **D**.
10. Guide the bottle until it is resting on the seal **E** of the dispenser group.

 **Important**

If the bottle doesn't sit properly, remove it and adjust the stopper **F to regulate the height of the dispenser group **G** based on the length of the bottle.**

(See “Bottle characteristics table 1 technical data)

11. Rotate the bottle slightly to the right and left to stabilise and centre it.

NOTE: Make sure the bottle mouth and spout of the dispenser group perfectly align to avoid microleaks.

12. Check that the filter of the wine straw is positioned on the bottom of the bottle.
 - DO NOT use wines with lots of sediment so as not to clog the filter of the wine straw.
 13. Close the door **B**.
 14. Press the key **H**.
 15. Follow the instructions shown on the display.
 16. Programme the dose and bottle volumes (See ““Bottle volume” screen (7e)” - ““Prices/Doses” screen (7c)”).
 17. Repeat the procedure to insert the other bottles.
 18. Extract the card from the reader **A**.
- The dispenser is configured to dispense the requested wine doses.**

Bottle insertion (wine same as previous)

⚠ Important

NEVER use bottles that are not completely full so as not to alter the data counted by the dispenser.

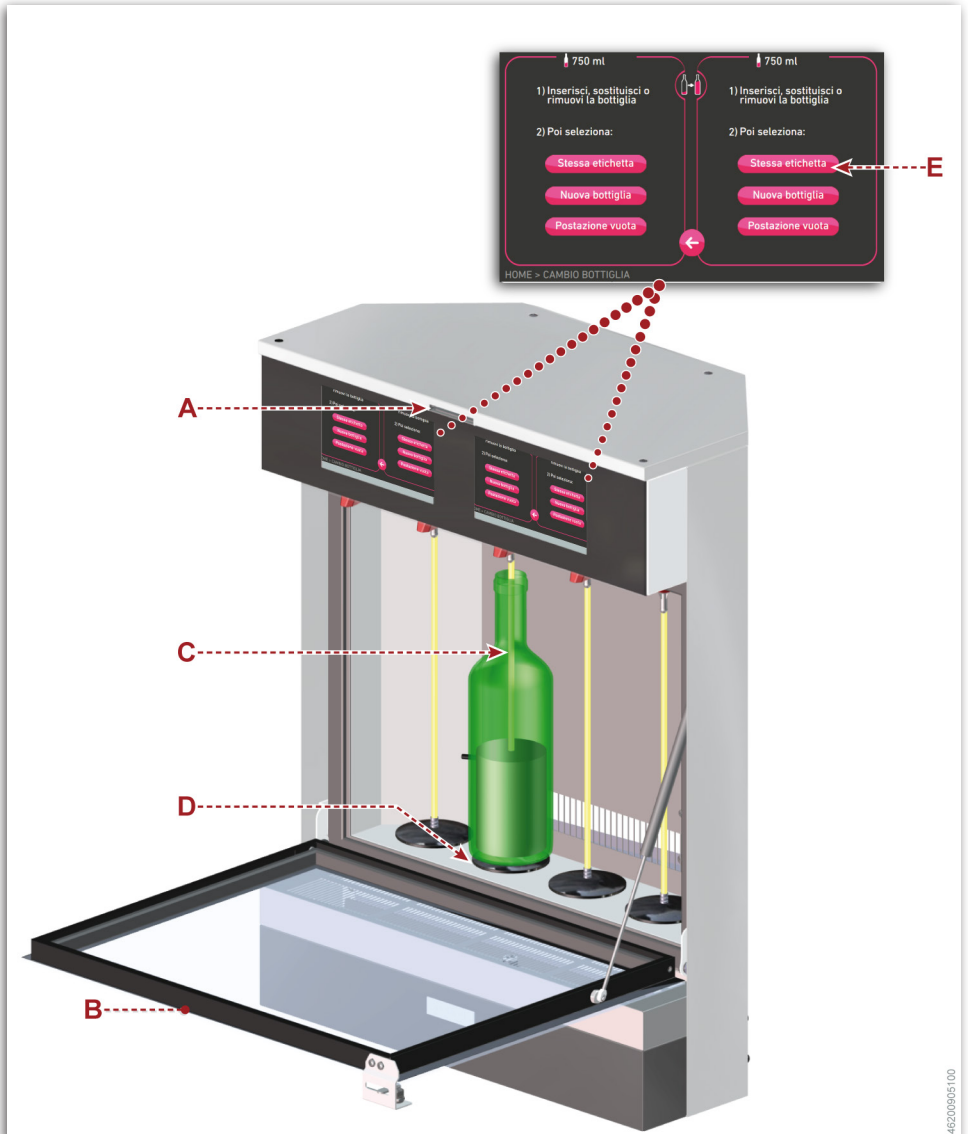

Proceed as indicated.

1. Insert the “MANAGER” or “STAFF” card in the reader **A**.
2. Open the door **B**.
3. Take out the empty bottle and leave the wine straw **C** in place.

NOTE: A small quantity of wine remains in the wine straw, which will be integrated with the wine in the new bottle.

4. Thoroughly clean the bottle mouth of any residue and check that there are no rough edges to avoid microleaks.
5. Insert the wine straw **C** in the new bottle and position it on the support **D**.
6. Check that the filter of the wine straw is positioned on the bottom of the bottle.

7. Rotate the bottle slightly to the right and left to stabilise and centre it.

NOTE: Make sure the bottle mouth and spout of the dispenser group perfectly align to avoid gas microleaks.

- DO NOT use wines with lots of sediment so as not to clog the filter of the wine straw.

8. Close the door **B**.
9. Press the key **E**.
10. Follow the instructions shown on the display.
11. Extract the card from the reader **A**.

The dispenser is configured to dispense the requested wine doses.

Bottle insertion (wine different to previous)

⚠ Important

NEVER use bottles that are not completely full so as not to alter the data counted by the dispenser.

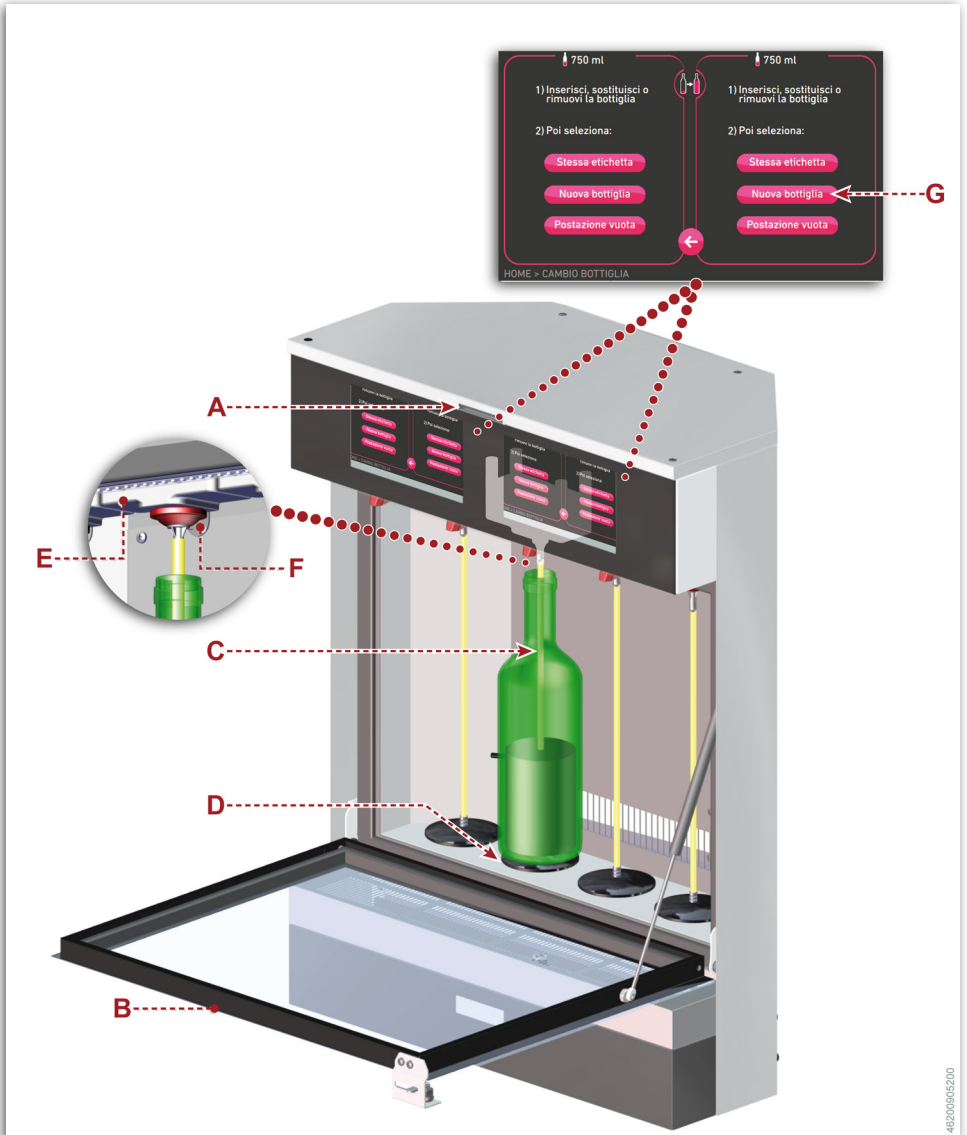

Proceed as indicated.

1. Insert the “MANAGER” or “STAFF” card in the reader **A**.
2. Open the door **B**.
3. Take out the empty bottle.
4. Extract the wine straw **C**.
5. Thoroughly clean the bottle mouth of any residue and check that there are no rough edges to avoid microleaks.
6. Clean and rinse the wine straw with drinking water.
7. Insert the wine straw **C** in the dispenser group (See “Preparation of wine straws”).
8. Uncork the bottle to be inserted in the dispenser.
9. Insert the wine straw **C** in the new bottle and position it on the support **D**.

 **Important**

If the bottle doesn't sit properly, remove it and adjust the stopper **F** to regulate the height of the dispenser group **G** based on the length of the bottle.

(See “Bottle characteristics table 1 technical data)

10. Rotate the bottle slightly to the right and left to stabilise and centre it.

NOTE: Make sure the bottle mouth and spout of the dispenser group perfectly align to avoid microleaks.

11. Check that the filter of the wine straw is positioned on the bottom of the bottle.
 - DO NOT use wines with lots of sediment so as not to clog the filter of the wine straw.
 12. Close the door **B**.
 13. Press the key **G**.
 14. Follow the instructions shown on the display.
 15. Programme the dose and bottle volumes (See ““Bottle volume” screen (7e)” - ““Prices/Doses” screen (7c)”).
 16. Extract the card from the reader **A**.
- The dispenser is configured to dispense the requested wine doses.**

Dispensing procedure (backdesk use)

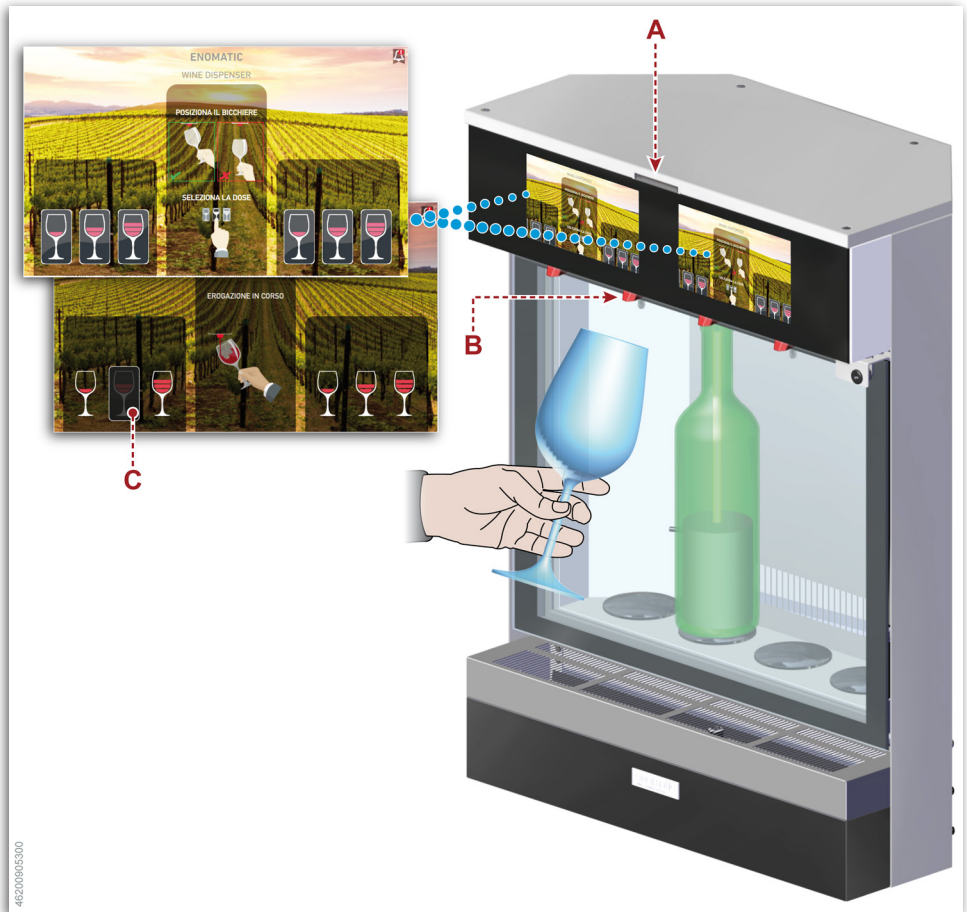

48200805300

Proceed as indicated.

1. Extract the card from the reader **A**.
2. Position the glass in correspondence with the pour spout **B**.
3. Press one of the buttons **C** to dispense the wine dose.
 - When the preset dose is reached the display returns to the initial view.

Dispensing procedure (use with winecard)

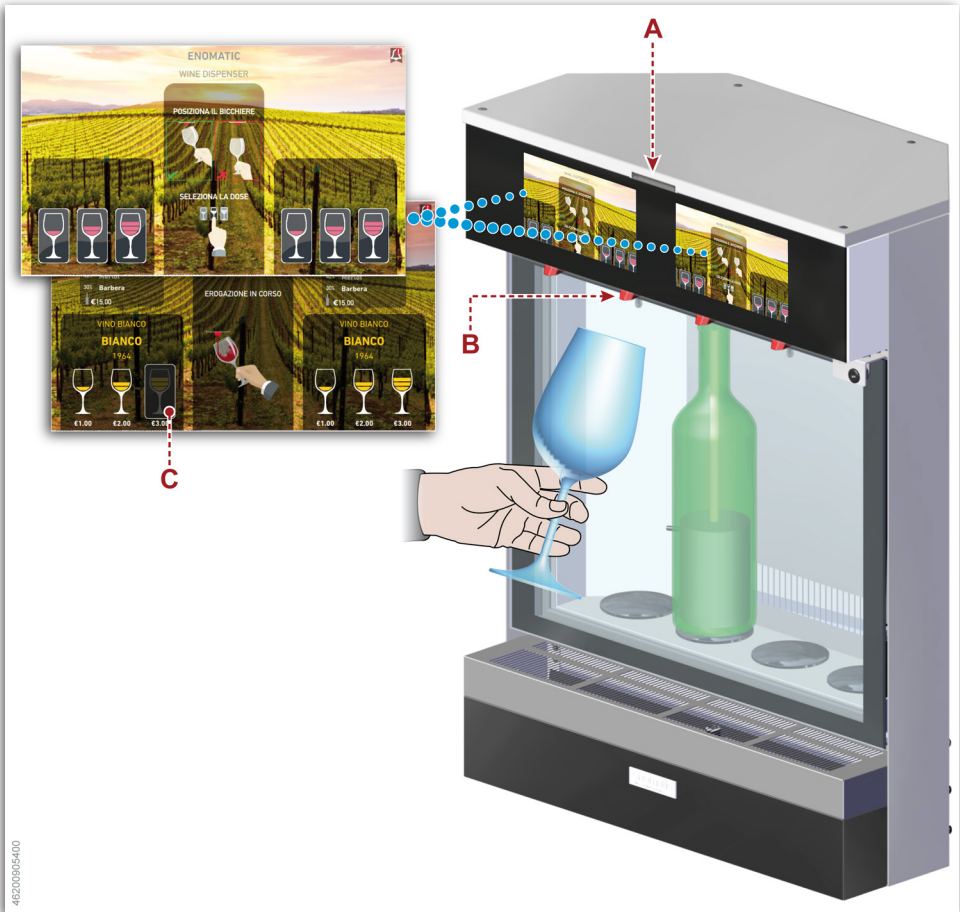

Proceed as indicated.

1. Insert the “User Card” correctly in the reader **A**.
2. Position the glass in correspondence with the pour spout **B**.
3. Press one of the buttons **C** to dispense the wine dose.

- When the preset dose is reached the display returns to the initial view.

NOTE: The price of the pour is automatically deducted from the card credit.

4. Extract the “User Card” from the reader **A**.

Extended non-use

If the dispenser remains inactive for a long period of time, follow the procedures described below.

1. Disable the refrigeration function.
2. Defrost the refrigeration system.
3. Sanitise the dispensers (See “Dispenser sanitisation”).
4. Empty the dispensers (See “Dispenser emptying”).
5. Enable the refrigeration function and disconnect the dispenser from the mains.
6. Close the cylinder tap (internal or external) and disconnect the tubes.
7. Remove and sanitise the wine straws (See “Sanitisation of wine straws”).
8. Clean the grate and drip tray (See “Cleaning of drip tray”).
9. Clean the air filters (See “Cleaning of front air filter” - “Cleaning of rear air filter”).
10. Clean all the internal and external surfaces of the dispenser.
11. Clean the condensate tray (See “Cleaning of condensate tray”).
12. Clean the door seal.
13. Leave the door slightly open to allow an air exchange.
14. Cover the dispenser with the appropriate TNT bag supplied.

Recommendations for maintenance

- Keep the dispenser in best operating conditions by regularly carrying out routine maintenance.
- Good maintenance will allow best performance and ensure the longest possible service life.
- Wear the intended personal protective equipment (PPE) in order to carry out the operations in safe conditions.
- The manufacturer declines all responsibility for damage to persons or property

caused by the use of non-original parts and/or by interventions that can modify the requirements of hygiene and safety without formal authorisation from the manufacturer.



Important

Clean the external parts of the dispenser using only a rag soaked in warm water, or else food-grade detergents. Do not use abrasive and/or corrosive products.

Routine maintenance schedule

Table 2: Maintenance intervals

<i>Frequency</i>	<i>Component</i>	<i>Action</i>
Each time the wine is changed	Dispensers	Rinsing (See “Dispenser rinsing”).
	Wine straw	Clean (See “Cleaning of wine straws”).
Every day	Dispenser	Clean the external surfaces of the dispenser with a damp rag or sponge (See “Table of cleaning products”).
	Drip tray	Clean (See “Cleaning of drip tray”).
	Pour spout cap	Clean (See “Cleaning of pour spout cap”).
Every week	Condensate tray	Clean (See “Cleaning of condensate tray”).
	Dispensers	Clean (See “Dispenser rinsing”).
Every month (*)	Wine straw	Clean (See “Cleaning of wine straws”).
	Pour spout cap	Clean (See “Cleaning of pour spout cap”).
	Dispensers	Sanitisation (See “Dispenser sanitisation”).
Every 6 months (*)	Wine straw	Sanitisation (See “Sanitisation of wine straws”).
	Pour spout cap	Sanitisation (See “Sanitisation of pour spout cap”).
	Wine straw	Replace
Every year	Seals	Check wear Replace damaged seals

(*) If sweet wines with accentuated sediment are dispensed, double the washing frequency.

Table of cleaning products

The table indicates the cleaning products recommended by the manufacturer.

Table: Cleaning products

<i>Specifications</i>	<i>Value</i>
Sanitation	
Product type	- Drinking water - Citric acid (powder)
Product preparation	- Dilute 5x tea spoons of citric acid in 750ml bottle of warm water, maximum 86°F
Washing	
Product type	- Drinking water - Citric acid (powder)
Product preparation	- Dilute 3x tea spoons of citric acid in 750ml bottle of warm water, maximum 86°F
Cleaning	
Product type	- Stainless Steel cleaner or warm water
Method of use	- Spray on a rag - Wipe the surface - Turn the rag over to the clean side and dry the surface.

Sanitisation of pour spout cap

Proceed as indicated.

1. Dismantle the spout covers **A**.
2. Submerge the components in a sanitising solution for 15 minutes (See “Table of cleaning products”).
3. Rinse the components with water at a maximum temperature of 100°F.
4. Perform the cleaning procedure (See “Cleaning of pour spout cap”).

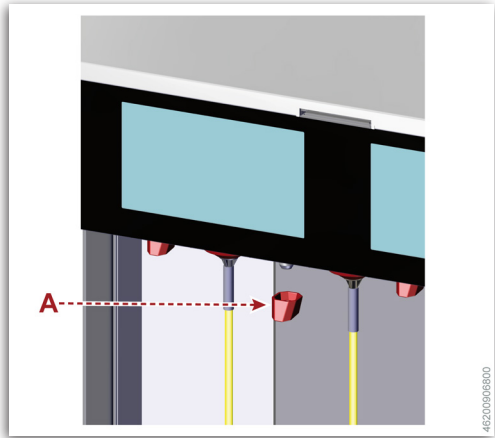

Sanitisation of wine straws

Proceed as indicated.

1. Dismantle the wine straws **A**.
2. Submerge the components in a sanitising solution for 15 minutes (See “Table of cleaning products”).
3. Rinse the components with water at a maximum temperature of 100°F.

NOTE: Rinsing must be carried out both internally and externally, paying careful attention to the cleanliness of the filter at the tip of the component.

4. Perform the cleaning procedure (See “Cleaning of wine straws”).

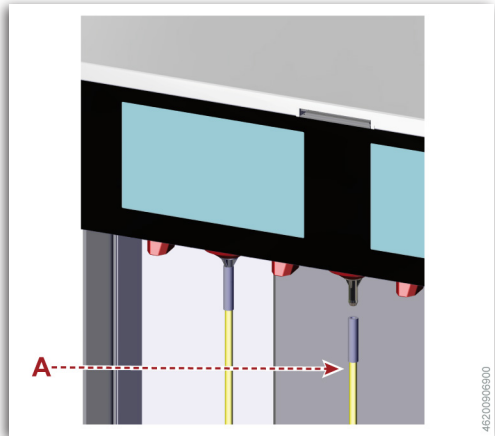

Dispenser sanitisation

Proceed as indicated.

1. Insert the “MANAGER” or “STAFF” card in the reader .
2. Remove the wine bottle from the dispenser group without opening the bottle management screen.
3. Fill an empty bottle with the sanitising solution (See “Table of cleaning products”).
4. Insert a new or sanitised wine straw in the bottle and place it on its respective support.
5. Press the key **A**.
6. Follow the instructions shown on the display.
7. Remove the bottle.
8. Perform the cleaning procedure (See “Dispenser cleaning”).

Each dispenser can be sanitised separately at different times, depending on bottle consumption.

NOTE: Sanitisation must also be performed every time (before and after) the dispenser is not used for long periods.

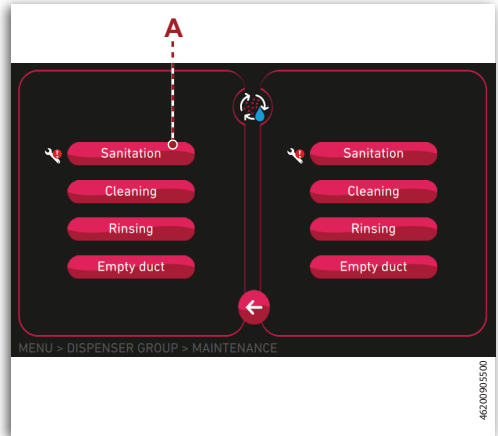

Dispenser cleaning

Proceed as indicated.

1. Insert the “MANAGER” or “STAFF” card in the reader .
2. Remove the wine bottle from the dispenser group without opening the bottle management screen.
3. Fill an empty bottle with the cleaning solution (See “Table of cleaning products”).
4. Insert the wine straw in the bottle and place it on its respective support.
5. Press the key **B**.
6. Follow the instructions shown on the display.
7. Remove the bottle.

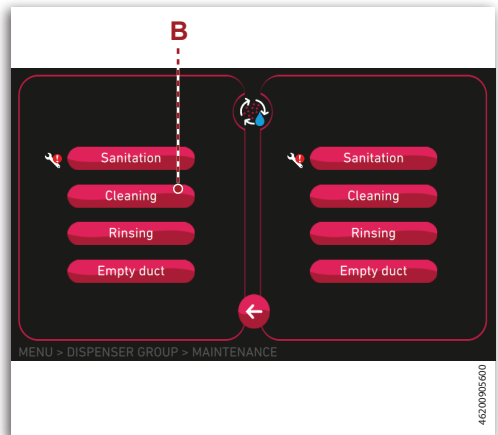

8. Perform the rinsing procedure (See “Dispenser rinsing”).

Each dispenser can be cleaned separately at different times, depending on bottle consumption.

Dispenser rinsing

Proceed as indicated.

1. Insert the “MANAGER” or “STAFF” card in the reader .
2. Remove the wine bottle from the dispenser group without opening the bottle management screen.
3. Fill an empty bottle with drinking water.
4. Insert the wine straw in the bottle and place it on its respective support.
5. Press the key **C**.
6. Follow the instructions shown on the display.
7. Remove the bottle.
8. Perform the emptying procedure (See “Dispenser emptying”).

Each dispenser can be rinsed separately at different times, depending on bottle consumption.

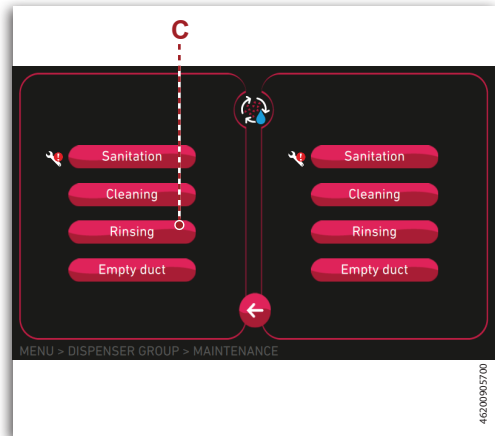

Dispenser emptying

Proceed as indicated.

1. Insert the “MANAGER” or “STAFF” card in the reader .
2. Remove the wine bottle from the dispenser group without opening the bottle management screen.
3. Insert the wine straw in an empty bottle and place it on its respective support.
4. Press the key **D**.
5. Follow the instructions shown on the display.
6. Remove the bottle.
7. Re-insert the wine bottle in the dispenser group.
8. Extract the card from the reader .

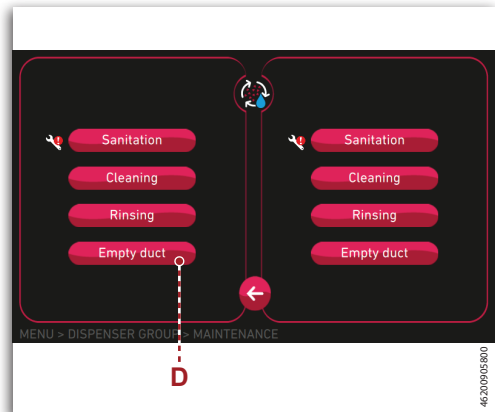

Cleaning of pour spout cap

Proceed as indicated.

1. Dismantle the spout covers **A**.
2. Wash the components with water at a maximum temperature of 100°F.

NOTE: Submerge the insufficiently clean components in a washing solution for 15 minutes (See “Table of cleaning products”).

3. Rinse the components with water at a maximum temperature of 104°F.
4. Leave the components to dry naturally in a clean place.
5. Assemble the spout covers.

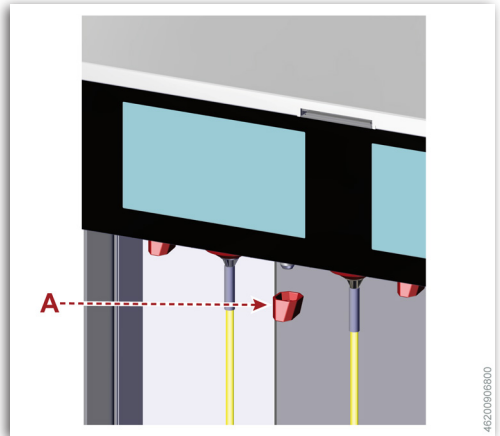

Important

Do not wash the components in the dishwasher and do not use detergents.

Cleaning of wine straws

Proceed as indicated.

1. Dismantle the wine straws **A**.
2. Wash the components with water at a maximum temperature of 100°F.

NOTE: Washing must be carried out both internally and externally, paying careful attention to the cleanliness of the filter at the tip of the component.

NOTE: Submerge the insufficiently clean components in a washing solution for 15 minutes (See “Table of cleaning products”).

3. Rinse the components with water at a maximum temperature of 100°F.

NOTE: Rinsing must be carried out both internally and externally, paying careful attention to the cleanliness of the filter at the tip of the component.

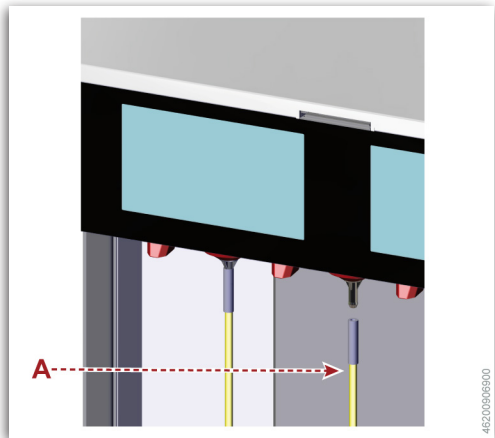

4. Shake the components vigorously to remove any residual internal liquid.
5. Leave the components to dry naturally in a clean place.
6. Assemble the wine straws.

Important

Do not wash the components in the dishwasher and do not use detergents.

Cleaning of drip tray

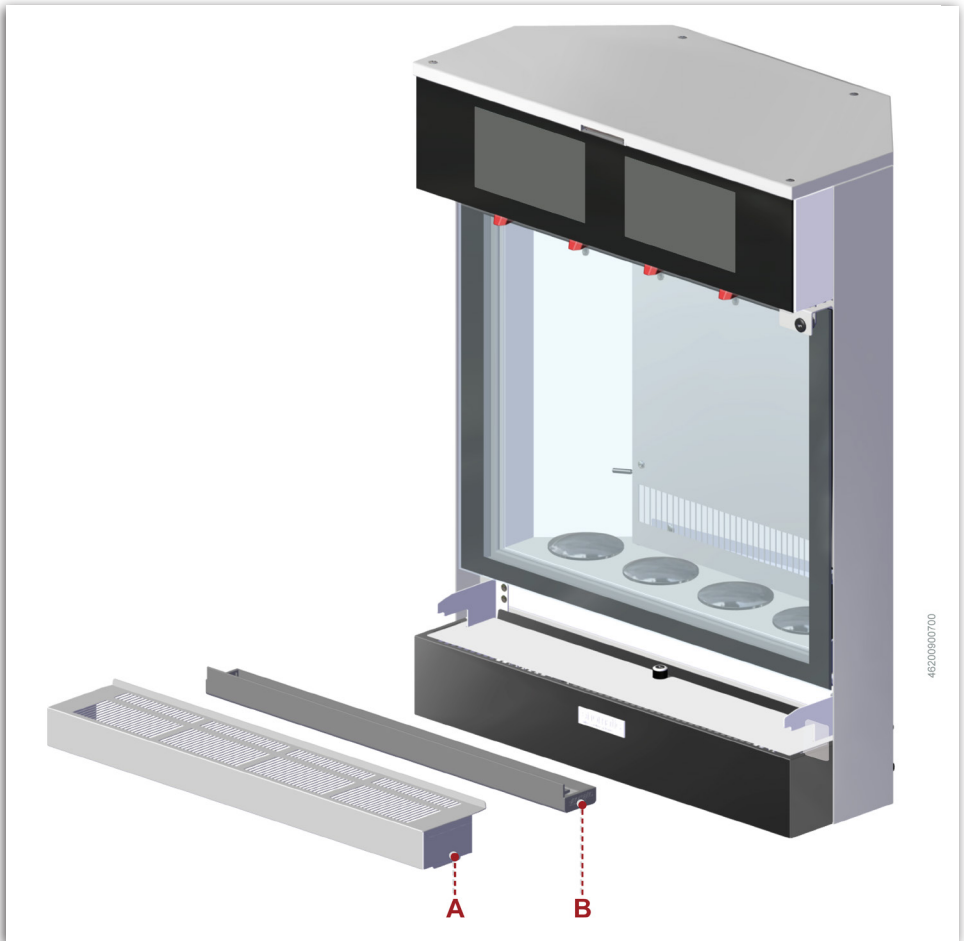

Proceed as indicated.

1. Remove the grate **A**.
2. Remove the drip tray **B**.
3. Empty the tray and clean it with water and a damp sponge.

4. Dry the tray.
5. Assemble the drip tray.
6. Assemble the grate **A**.

Important

Do not wash the components in the dishwasher and do not use detergents.

Cleaning of front air filter

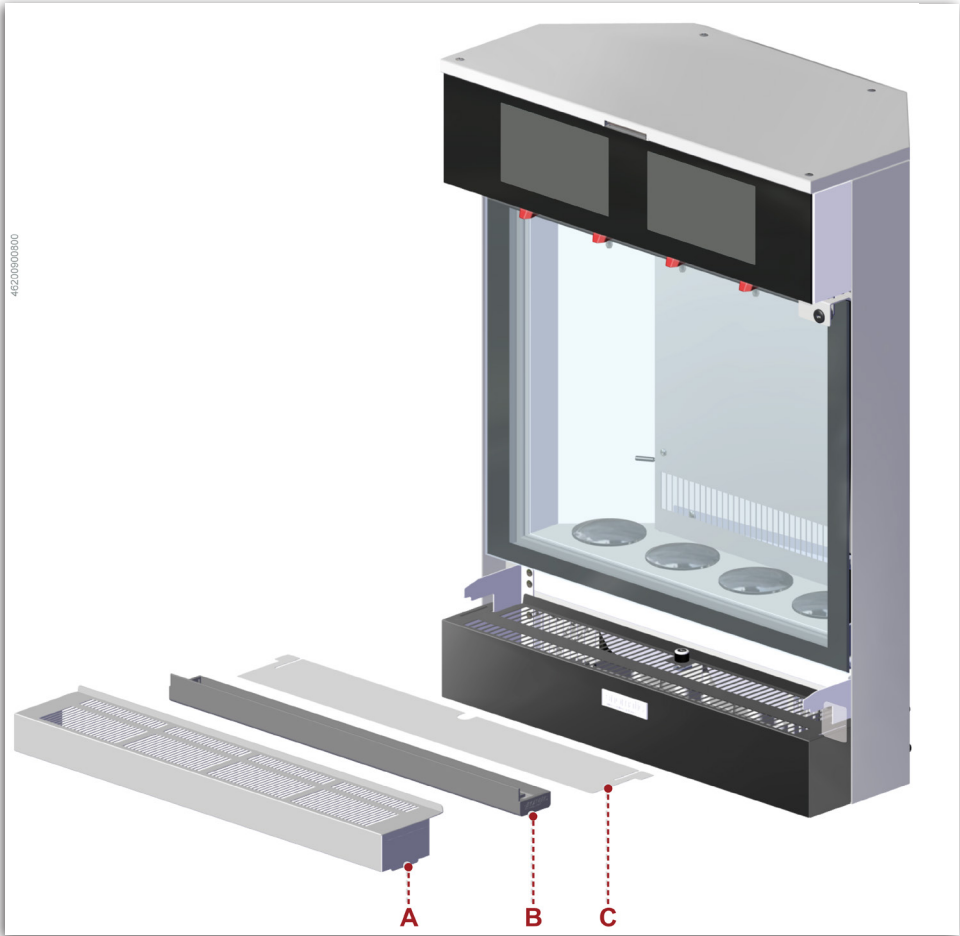

Proceed as indicated.

1. Remove the grate **A**.
2. Remove the drip tray **B**.
3. Dismantle the filter **C**.
4. Clean the filter with water and a damp sponge.

NOTE: Replace the filter with an original spare filter if it appears damaged.

5. Dry the filter.
6. Assemble the filter.
7. Assemble the drip tray **B**.
8. Assemble the grate **A**.

⚠ Important

Do not wash the components in the dishwasher and do not use detergents.

Cleaning of rear air filter

Important

Operation to be performed by the manufacturer's authorised expert technicians

- Proceed as indicated.
- 1. Stop the dispenser (See "Stop").
- 2. Disconnect the plug from the electrical power socket.
- 3. Remove the grate **A**.
- 4. Dismantle the filter.
- 5. Clean the filter with dry compressed air (Max 4 bar).

NOTE: Replace the filter with an original spare filter if it appears damaged.

- 6. Assemble the filter.
- 7. Assemble the grate **A**.

Important

Do not wash the components in the dishwasher and do not use detergents.

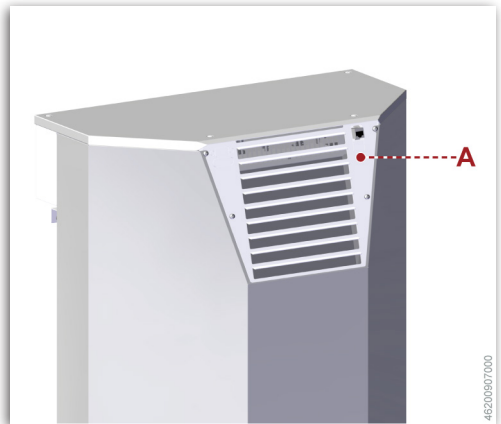

Cleaning of condensate tray

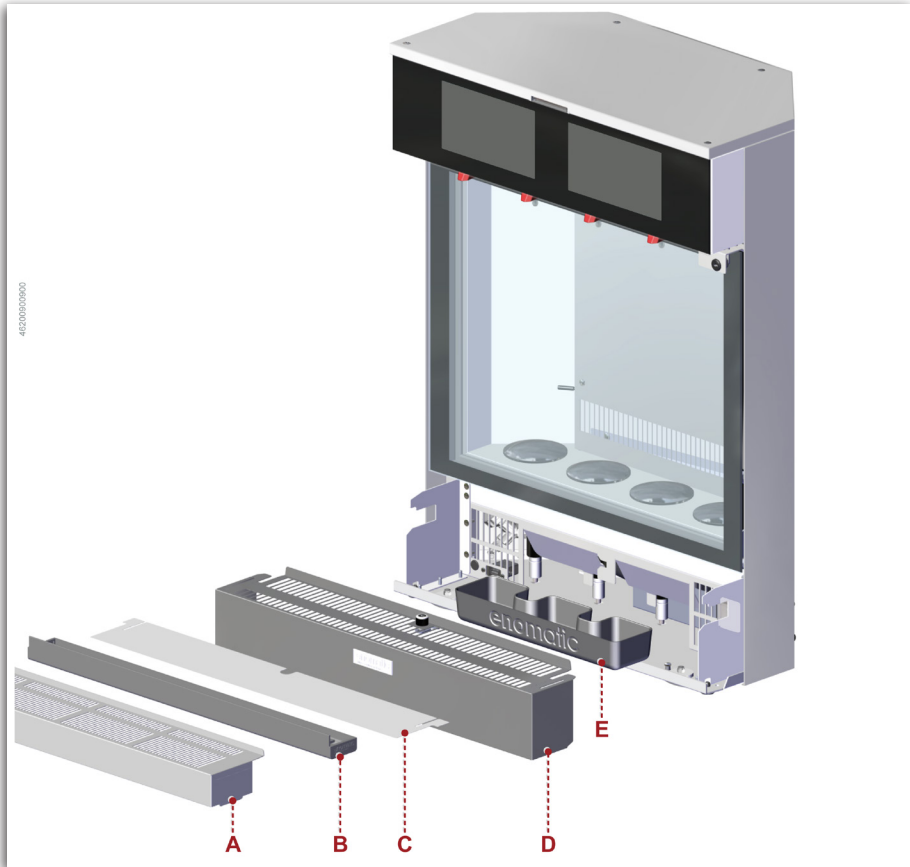

Proceed as indicated.

1. Remove the grate **A**.
2. Remove the drip tray **B**.
3. Dismantle the filter **C**.
4. Release the protection **D**, using the key, and remove it.
5. Dismantle the tray **E**.
6. Empty the tray and clean it with water and a damp sponge.
7. Dry the tray.
8. Assemble the tray.
9. Assemble the protection **D** and block it with the key.
10. Assemble the filter **C**.
11. Assemble the drip tray **B**.
12. Assemble the grate **A**.

⚠ Important

Do not wash the components in the dishwasher and do not use detergents.

Replacement of external cylinder

Replace the cylinder as soon as the gas operating pressure drops to 1 bar.

Important

Always have a reserve cylinder.

– Proceed as indicated.

1. Close the gas feed tap **A**.
2. Close the cylinder tap **B**.

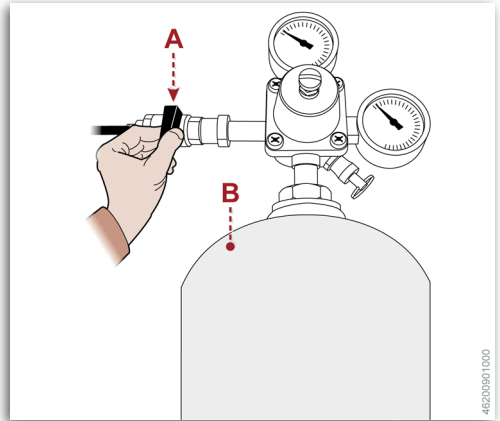

3. Pull the valve ring **C** (if present) and hold it in position to release the residual cylinder pressure **B**. Release it only once the pressure gauges **D-E** indicate a value of 0 (zero).

Caution - Warning

Do not approach parts of the drain valve body to avoid abrasions.

4. Dismantle the regulator unit and replace the cylinder **B**.
5. Check the condition of the seal and replace it if necessary.

Important

Use only “food-grade” seals.

6. Assemble the regulator unit in the new cylinder **B**.

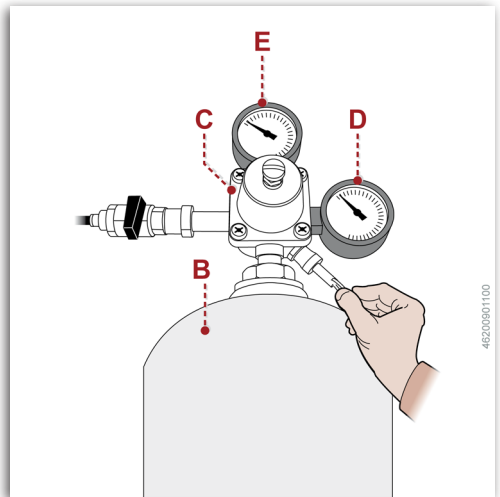

7. Open the cylinder tap **B**.
8. Re-open the gas feed tap **A**.

⚠ Important
Do not dispose of polluting material in the environment. Dispose of it in compliance with the applicable laws in force.

⚠ Important
Use only Food-grade Gases such as Argon (E938) or Nitrogen (E941).

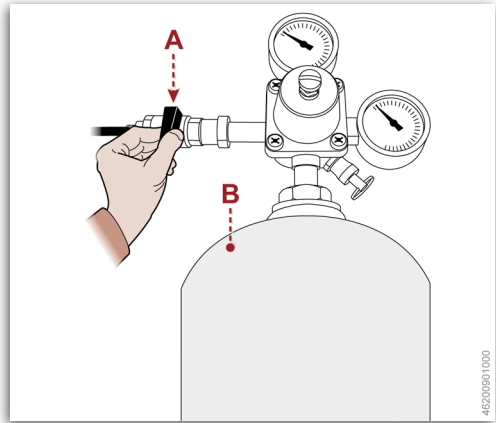

Replacement of internal cylinder

Replace the cylinder as soon as an alert is sent by the dispenser.

⚠ Important
Always have a reserve cylinder.

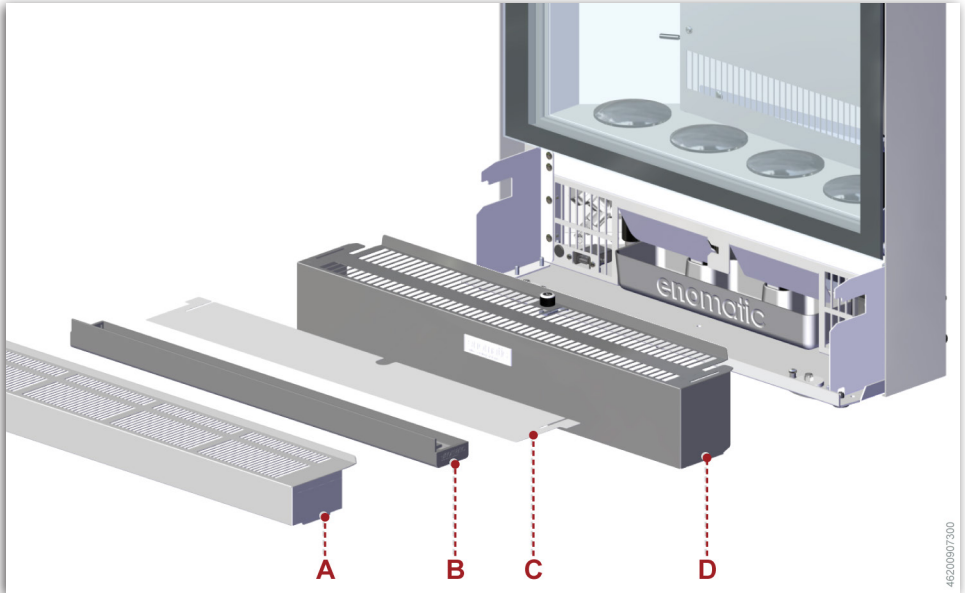

– Proceed as indicated.

1. Remove the grate **A**.
2. Remove the drip tray **B**.

3. Dismantle the filter **C**.
4. Release the protection **D**, using the key, and remove it.
5. Remove the cylinder **E**.
6. Close the cylinder tap **F**.
7. Unscrew the cylinder **E** and replace it.
8. Operate the tap **F** to adjust the gas pressure.
- The operating pressure is 4 bar
9. Position the cylinder **E**.

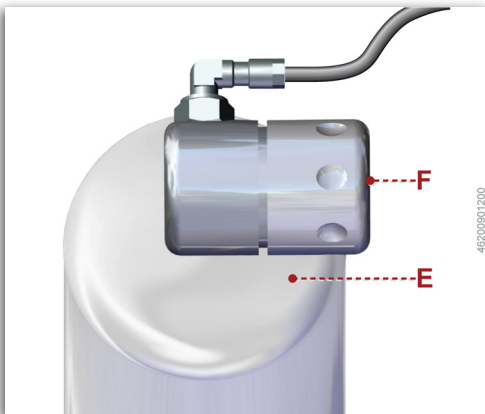

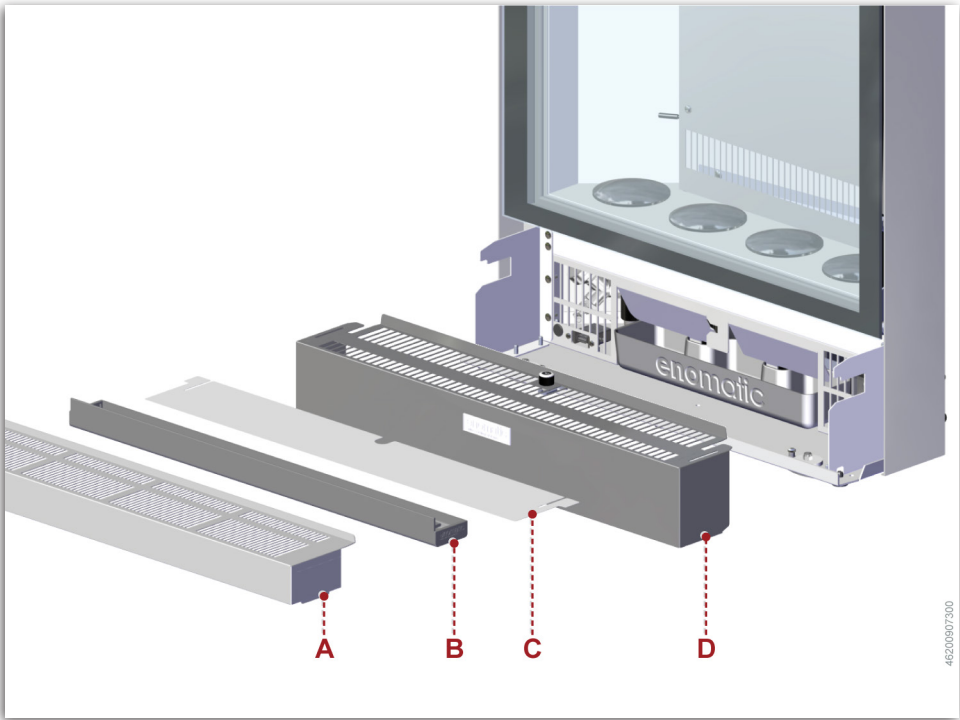

10. Assemble the protection **D** and block it with the key.
11. Assemble the filter **C**.
12. Assemble the drip tray **B**.
13. Assemble the grate **A**.

⚠ Important

Do not dispose of polluting material in the environment. Dispose of it in compliance with the applicable laws in force.

⚠ Important

Use only Food-grade Gases such as Argon (E938) or Nitrogen (E941).

Troubleshooting

The dispenser is tested prior to being placed into service.

- The scope of the following information is to assist in the identification and correction of any errors and malfunctions that may occur during use.
- Some of these problems can be resolved by the user, all other problems require specific technical knowledge or special skills and therefore must be carried out only by qualified personnel with recognised experience acquired in the specific field of reference.
- The table provides a list of errors that may occur during normal operation and indicates the possible remedies.

Table 3: Operating errors

<i>Problem</i>	<i>Cause</i>	<i>Remedy</i>
The dispenser doesn't turn on	No power on the electrical supply line.	Check the electrical connection
	Electrical power not activated	Activate the electrical power supply (See "Start").
	Damaged power cord	Contact the manufacturer's authorised Help Service
	The dispenser is in "Stop" mode	Insert a card in the reader.
The dispenser doesn't reach the set temperature	Unsuitable ambient conditions	Position the dispenser in a suitable environment (See "Technical data").
	Dispenser not correctly installed.	Install correctly (See "Installation and connection").
	The refrigeration unit is not sufficiently ventilated (for example, the air vents are blocked) or has malfunctioned.	Restore the ventilation conditions of the refrigeration unit or have it replaced by the manufacturer's authorised Help Service
	Door not properly closed.	Close the door.
	Temperature not properly regulated	Carry out regulation (See ""Refrigeration" screen (10g)").
	Refrigeration system not activated.	Activate the refrigeration system (See ""Refrigeration" screen (10g)").
	Ice in the bottle compartment.	Defrost the compartment (See ""Refrigeration" screen (10g)").

<i>Problem</i>	<i>Cause</i>	<i>Remedy</i>
The dispenser compartments have a different temperature to that declared. (For model 8/R only)	Presence / Absence of compartment divider.	The divider must be removed with the left cell set to 64°F.
Excessive condensate in the bottle compartment.	Door not properly closed.	Close the door.
	Door left open for too long.	Limit the door opening time.
	Unsuitable ambient conditions	Position the dispenser in a suitable environment (See "Technical data").
All or some of the dispenser doses are disabled or are not displayed.	Worn seals	Replace the seals
	Bottle missing or not properly inserted.	Properly insert the bottle.
	There isn't enough wine in the bottle to dispense the corresponding dose	Select a different dose or replace the bottle
	Dose key not properly regulated.	Carry out regulation (See "Prices/Doses" screen (7c)).
The bottle support doesn't stay in the blocked position.	Bottle volume not properly regulated.	Carry out regulation (See "Bottle volume" screen (7e)).
	The support hasn't been pushed all the way down.	Push the support until the blocked position.
The bottle support doesn't lift	Support seat blocked.	Remove any foreign objects in the support seat.
	The support hasn't been pushed until the release.	Push the support down properly.
The LEDs for internal lighting don't light up.	Gas spring missing or faulty.	Insert a working gas spring.
	Components not properly positioned.	Properly reposition the gas spring and the support.
The LEDs for external lighting don't light up.	LED not properly regulated.	Carry out regulation (See "Brightness" screen (9c)).
The LEDs for external lighting don't light up.	LED not properly regulated.	Carry out regulation (See "Brightness" screen (9c)).

<i>Problem</i>	<i>Cause</i>	<i>Remedy</i>
The wine isn't dispensed consistently	Bottle missing or not properly inserted.	Properly insert the bottle.
	The wine straw isn't properly inserted in the dispenser group	Remove the bottle and push the wine straw until it is completely inserted in the dispenser group
	The wine straw filter is clogged	Clean the wine straw or replace it.
	The wine straw is clogged or is of incorrect length.	Clean the wine straw or replace it.
	The gas in the wine dispensing circuit is finished or the feed pressure is insufficient	Restore the correct gas feed conditions
	The dispenser group valves are clogged by wine sediment	Sanitise the dispenser group (See "Dispenser sanitisation").
	Plug tap seal is worn or out of position.	Replace or reposition the seal.
	Damaged gas feed tube	Contact the manufacturer's authorised Help Service
Wine drops continuously leak from the dispenser.	Dispenser not properly calibrated.	Carry out calibration (See "Calibration" screen (7d)).
	Sediment is preventing the correct closure of the dispenser group valves.	Sanitise the dispenser group (See "Dispenser sanitisation").
The gas cylinder empties too quickly.	Damaged gas feed tube	Contact the manufacturer's authorised Help Service
	The gas feed tube connection is defective	Restore the correct gas feed conditions (See "Installation and connection").
	The bottle doesn't properly adhere to the dispenser group	Properly align the bottle mouth with the dispenser group
The dispenser doesn't connect to the data network.	Network cable disconnected.	Connect the network cable
	Wi-Fi connection disabled.	Enable the Wi-Fi connection (See "Connectivity" screen (10b)).
	Incorrect network connection parameters.	Insert the correct parameters (See "Connectivity" screen (10b)).

<i>Problem</i>	<i>Cause</i>	<i>Remedy</i>
The sensory properties of the wine are altered or unpleasant.	Incorrect gas type.	Use the indicated gas (See "Technical data").
	The gas is finished.	Replace the gas cylinder.
	The bottle doesn't properly adhere to the dispenser group	Properly align the bottle mouth with the dispenser group
	The wine in the bottle was already altered.	Ensure the quality of the bottle of wine before inserting it in the dispenser.
	More than 21 days have passed since the bottle was inserted.	Replace the bottle. Sanitise the dispenser group (See "Dispenser sanitisation").
	Temperature not properly regulated	Carry out regulation (See ""Refrigeration" screen (10g)").
	Routine maintenance was not properly performed on the dispenser group.	Sanitise the dispenser group (See "Dispenser sanitisation").
	Routine maintenance was not properly performed on the wine straws.	Sanitise the wine straws or replace them (See "Sanitisation of wine straws").
	A different type of wine was inserted without replacing the wine straw or without cleaning the dispenser.	Clean the dispenser and replace the wine straw with a clean or new one.

Decommissioning and demolition

- During decommissioning, it is necessary to perform a series of actions to ensure that the dispenser is not an obstruction, is not easily accessible and cannot be used.
- During demolition, sort all the components according to their chemical characteristics and arrange for differentiated disposal in compliance with the applicable laws in force.
- Do not dispose of non-biodegradable products, lubricating oils or non-ferrous components (rubber, PVC, resins, etc.) in the environment. Carry out their disposal in compliance with the applicable laws in force.

Licences

After entering the enotecha portal, the licences used in this product can be downloaded in the “Dispenser Info” section.

<https://enotecha.enomatic.net/>

Analytical Index

B

Bottle insertion (wine different to previous) .. 51
Bottle insertion (wine same as previous)..... 49

C

Cleaning, dispenser..... 59
Cleaning of condensate tray..... 66
Cleaning of drip tray 63
Cleaning of front air filter 64
Cleaning of pour spout cap..... 61
Cleaning of rear air filter 65
Cleaning of wine straws..... 62

D

Decommissioning and demolition..... 75
Description of cards..... 12
Description of dispenser, general 9
Description of display (for backdesk)..... 12
Description of display (for winecard) 13
Description of display (Manager Card) (1).... 15
Description of display (Staff Card) (1a) 16
Description of main parts..... 10
Documentation, attached..... 4

E

Emptying, dispenser 60

F

First bottle insertion 47

G

Glossary of terms 5

H

Handling and lifting 38

I

Identification of manufacturer and dispenser.... 4

Inspection of “packing list” and integrity of
dispenser 39
Installation and connection 39
 Electrical connection 43
 Gas connection (with external cylinder) 41
 Gas connection (with internal cylinder)..... 42

L

Licences 76

M

Management of dispenser from remote
devices (S3App)..... 33

N

Non-use, extended 55

P

Packing and unpacking 37
Preparation of wine straws 46
Procedure, dispensing (backdesk use) 53
Procedure, dispensing (use with winecard) .. 54
Procedure, request for assistance 4
Procedure, start and stop, dispenser..... 44
 Start 44
 Stop 32, 45
Purpose of the manual 3

R

Recommendations for installation and
connection 39
Recommendations for maintenance..... 56
Replacement of argon cylinder..... 69
Replacement of nitrogen cylinder..... 67
Rinsing, dispenser 60

S

Safety warnings for environmental impact 7
Safety warnings, general..... 6
Sanitisation of dispenser 59
Sanitisation of pour spout cap 58
Sanitisation of wine straws 58

Screen, “Bottle management” (2) 16
 Screen, “Bottle volume” (7e)..... 20
 Screen, “Brightness” (9c)..... 24
 Screen, “Buzzer volume” (9d)..... 24
 Screen, “Calibration” (7d) 20
 Screen, “Connectivity” (10b)..... 25
 Ethernet 25
 Wi-Fi 25
 Screen, “Data” (10e)..... 29
 Screen, “Dispenser group” (7) 18
 Screen, “INFO” (7a)..... 18
 Screen, “INFO” (10a)..... 25
 Screen, “Local settings” (9b) 22
 Currency 23
 Date/Time 22
 Language 22
 Unit 23
 Screen, “Maintenance” (7b)..... 19
 Screen, “Manager login” (11)..... 33
 Screen “Menu” (6) 18
 Screen, “Operating mode” (10c)..... 26
 Operating mode 26
 Options, operation 27
 Options, views 28

Screen, “PIN management” (10d) 29
 Screen, “Prices/Doses” (7c) 19
 Screen, “Refrigeration” (10g)..... 30
 General 30
 Info 32
 Temperature 31
 Screen, “Reset” (10f)..... 30
 Screen, “Settings” (8) 21
 Screen, “Stop” (10h)..... 32
 Screen, “User” (9)..... 21
 Screen, “Wallpaper” (9a) 21
 Screen, “Warnings” (5) 17
 Standard accessories 36

T

Table of cleaning products 57
 Table, Routine maintenance schedule.. 56
 Technical data 34
 Transportation and storage 37
 Troubleshooting 71

MANUFACTURED BY:

Enomatic S.R.L.

Via di Meleto, 1 int. 27

50022 Strada in Chianti, Florence - Italy

DISTRIBUTED BY:

FOR SERVICE PLEASE CONTACT:

enomatic[®]
wine serving systems

www.enomatic.com